

- NOTES**
- FOUR BASE OPTIONS ARE DETAILED TO SUIT THE RELEVANT COUPLING ARRANGEMENT.
 - THE REQUIRED BASE FOR THE SIDE & END VIEWS SHOULD BE LOADED TO MTG POSITION INDICATED.
 - * REMOVAL ALLOWANCE REQUIRED.

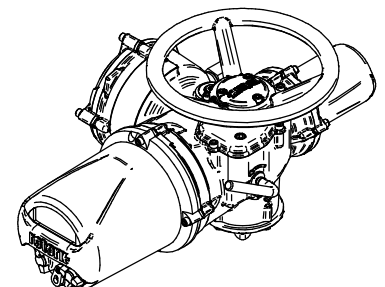

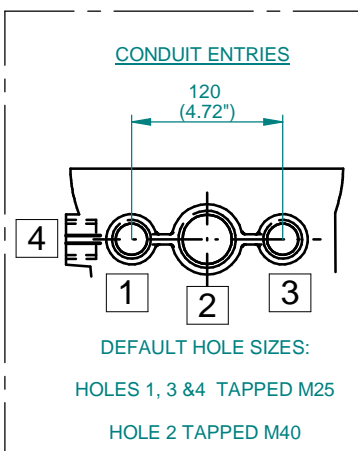

- NOTES**
- FOUR BASE OPTIONS ARE DETAILED TO SUIT THE RELEVANT COUPLING ARRANGEMENT.
 - THE REQUIRED BASE FOR THE SIDE & END VIEWS SHOULD BE LOADED TO MTG POSITION INDICATED.
 - 1*1 REMOVAL ALLOWANCE REQUIRED.

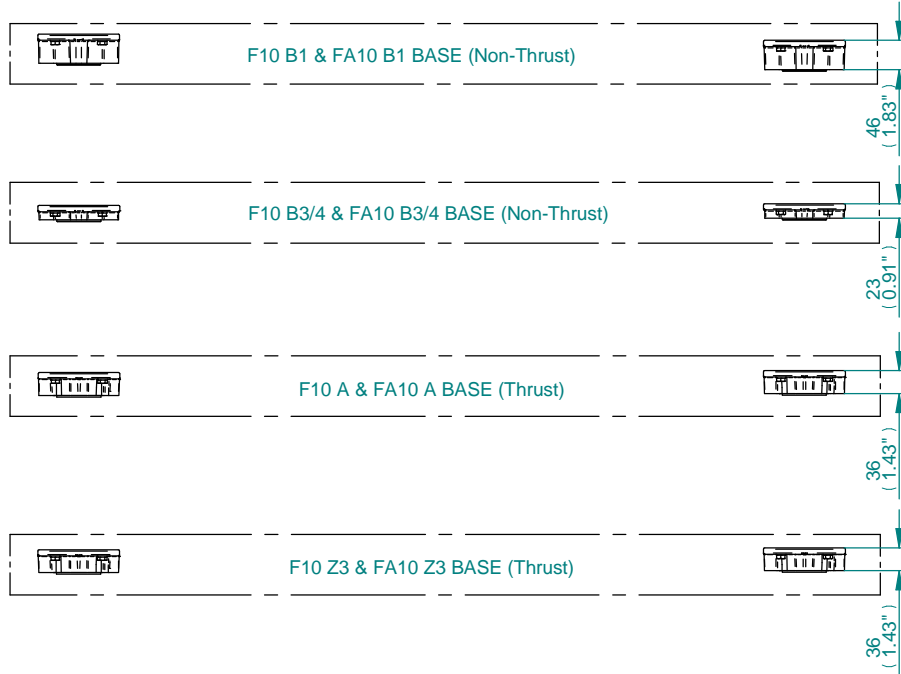
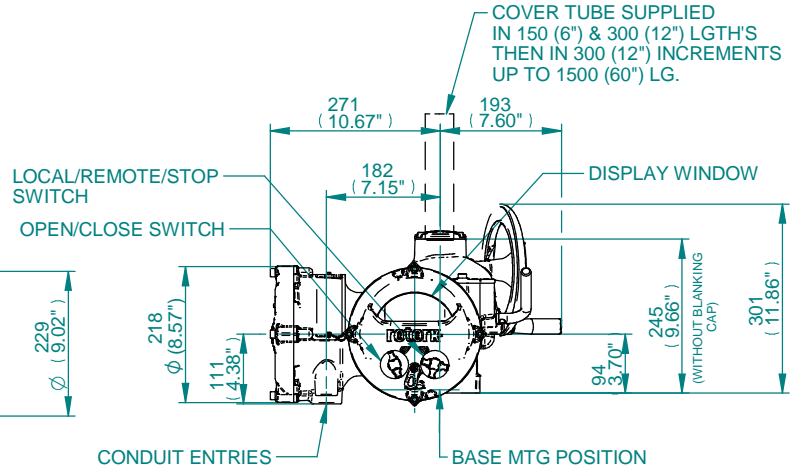
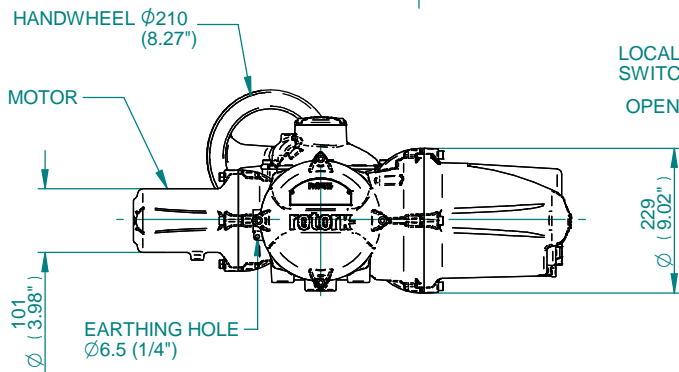
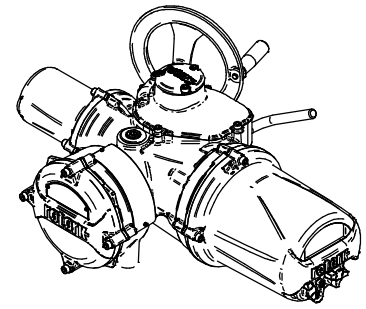
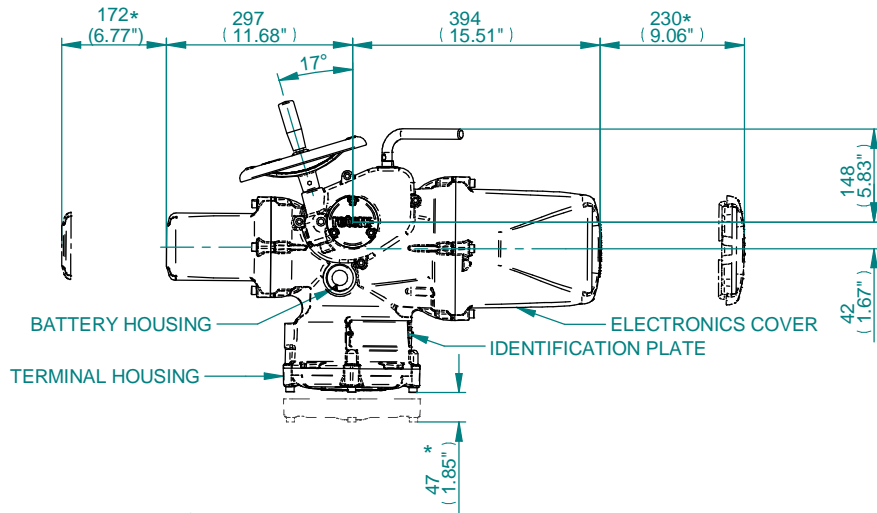
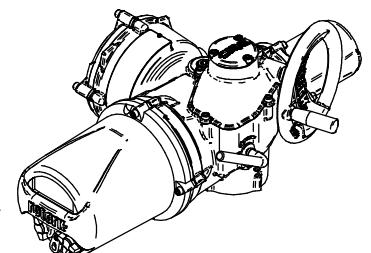

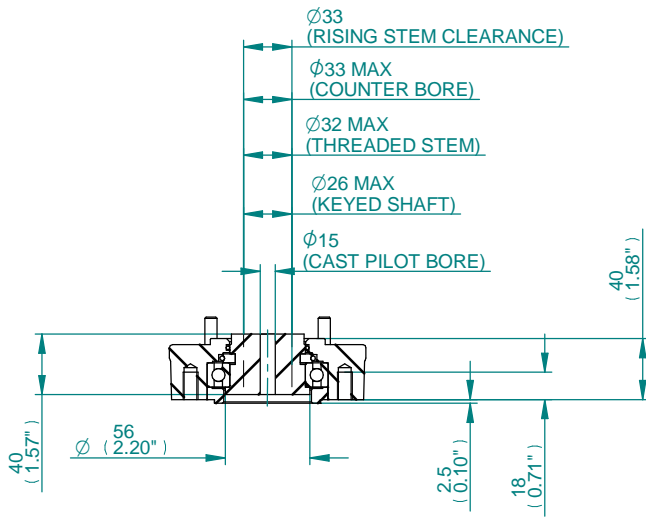

TYPE 'A' COUPLING DETAILS

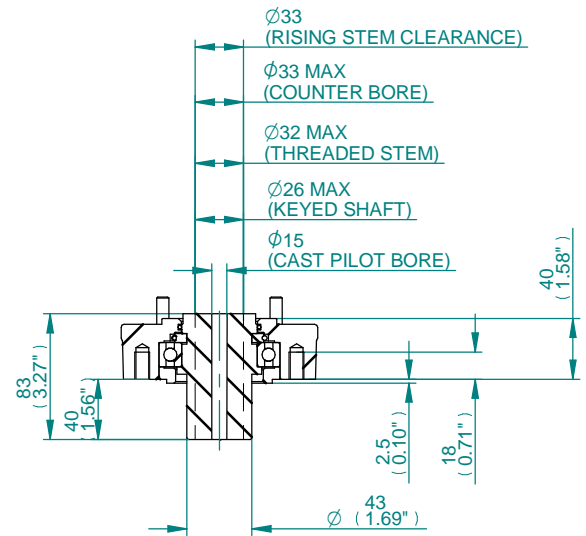

TYPE 'Z3' COUPLING DETAILS

NOTE : COUPLINGS WITHOUT PILOT BORE AVAILABLE IF SPECIFIED WITH ORDER.

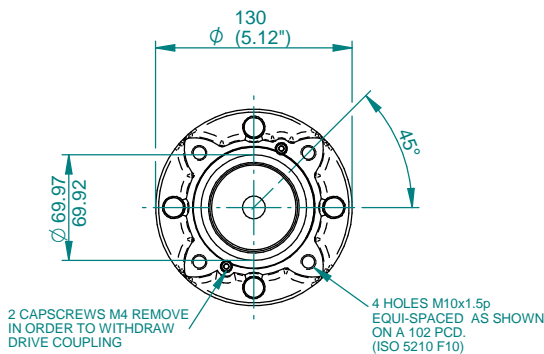

F10 BASE DETAILS FOR 'A' & 'Z3' COUPLINGS

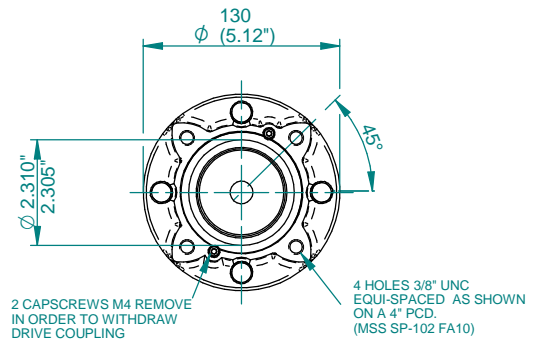

FA10 BASE DETAILS FOR 'A' & 'Z3' COUPLINGS

IQ3 SIZE 10-18 THRUST BASES

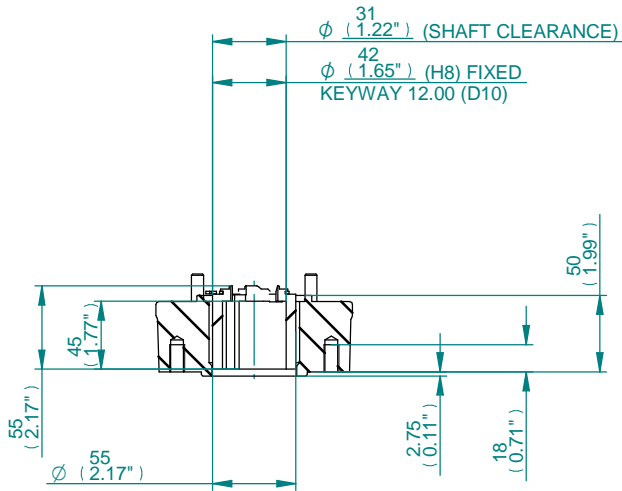

**TYPE 'B1'
COUPLING DETAILS**

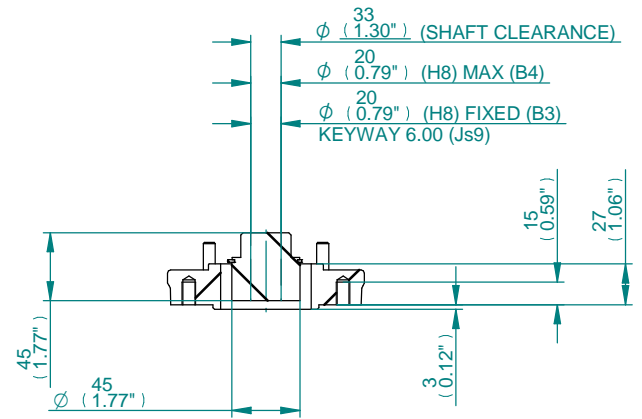

**TYPE 'B3/B4'
COUPLING DETAILS**

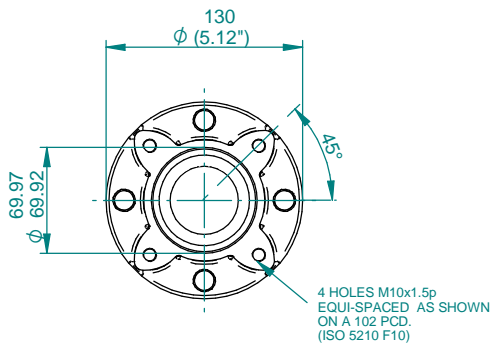

**F10 BASE DETAILS
FOR 'B1' & 'B3/B4' COUPLINGS**

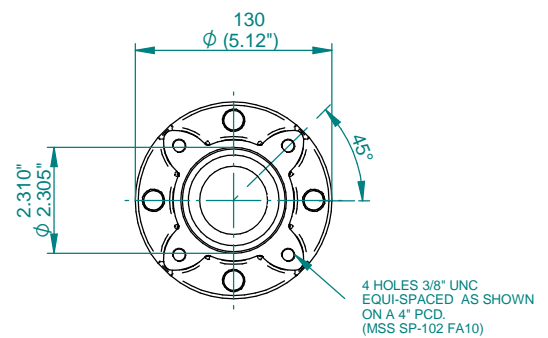

**FA10 BASE DETAILS
FOR 'B1' & 'B3/B4' COUPLINGS**

**IQ3 SIZE 10-18
NON-THRUST BASES**