

LEVER POSITION IN AUTO.  
LEVER AUTOMATICALLY RETURNS  
TO THIS POSITION WHEN RELEASED

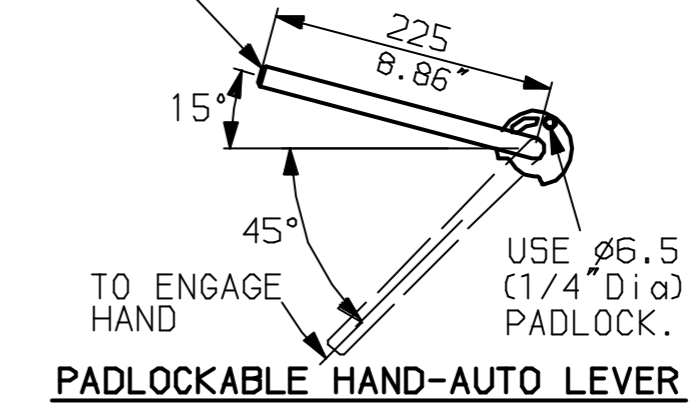

NOTES:  
DIMENSIONS WITH '\*' INDICATE COVER REMOVAL ALLOWANCE  
NETT WEIGHT = 74kg (163lbs)  
⊙ = OIL FILLER/DRAIN PLUG  
THE INTERFACE PROVIDED FOR MOUNTING THE ACTUATOR OR SECOND STAGE GEARBOX ONTO THE VALVE SHOULD CONFORM TO GOOD ENGINEERING PRACTICES, ENSURING ADEQUATELY TOLERANCED LIMITS FOR PARALLELISM, PERPENDICULARITY AND CONCENTRICITY.

**CONDUIT ENTRIES** (N.T.S)

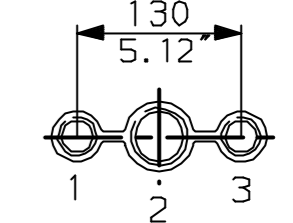

Nos.1 & 3 TAPPED 1" NPT  
No.2 TAPPED 1 1/2" NPT  
STD ALTERNATIVES IF SPECIFIED  
2 X M25, 1 X M40  
2 X PG16, 1 X PG29

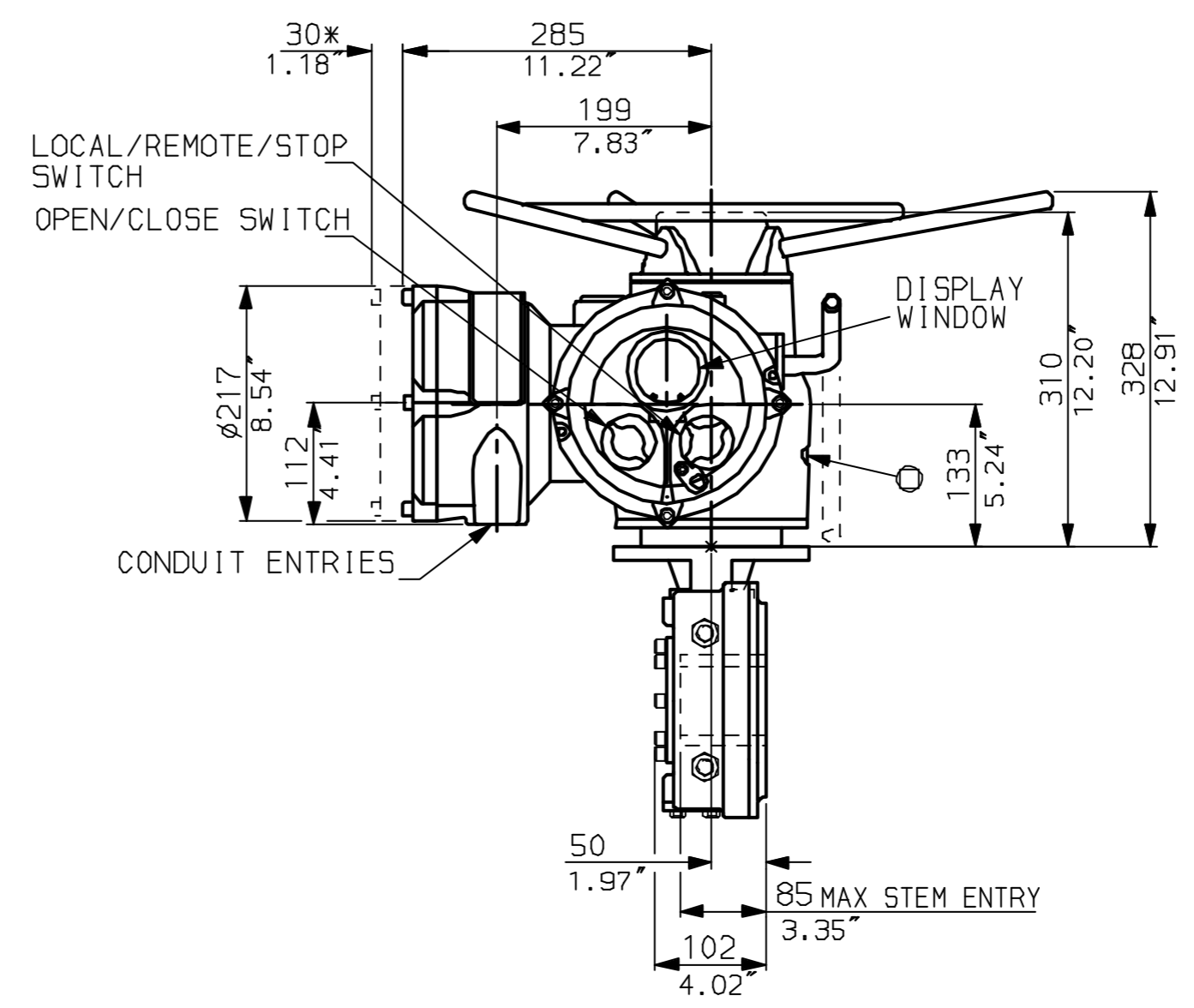
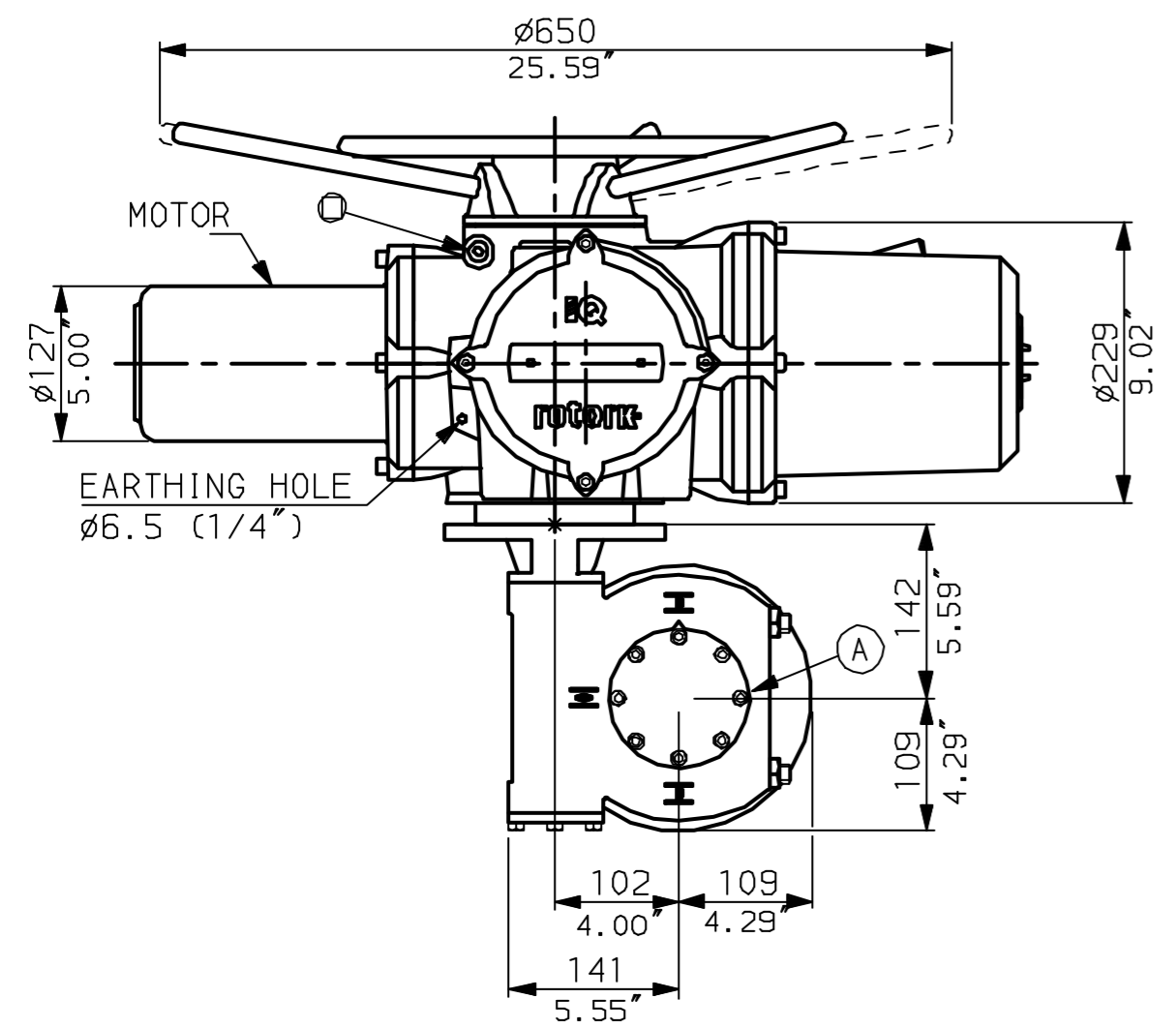

N.B. KEYWAY POS. CAN BE MOVED 90 OR 180° BY REMOVING 8 SCREWS MARKED (A) AND ROTATING OUTPUT SLEEVE.

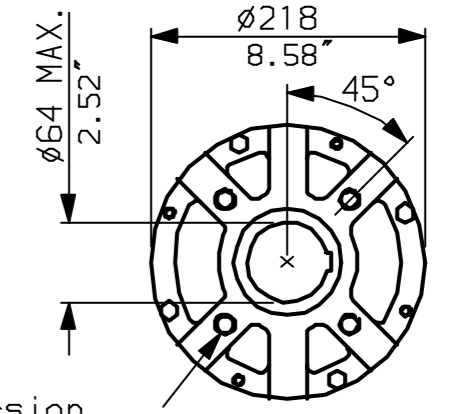

"F" version  
4 HOLES TAPPED M16 x 16 DP  
EQUI-SPACED AS SHOWN ON A  
140 PCD (ISO 5211-F14).

"FA" version  
4 HOLES TAPPED 5/8" UNC x 0.63" dp  
EQUI-SPACED AS SHOWN ON A  
5.5" PCD (MSS SP101-FA14).



Rotork Controls Ltd.  
Bath England, BA1 3JQ.  
(Phone 01225-733200)  
Rotork Controls Inc.  
Rochester, NY 14624  
(Phone 585-328-1550)

Title IQ20, 25 (+IQS20), THW, IW4,		
STANDARD DIMENSIONAL DATA		
Drawn CAD	Checked PRE	Ref Data Sheet
Date April 04	Job No IQ2THW_IW4	

01	First Issue.
Scale	1:6 THIRD ANGLE PROJECTION
Drawing Number	IQ2THW_IW4

G  
F  
E  
D  
C  
B  
A

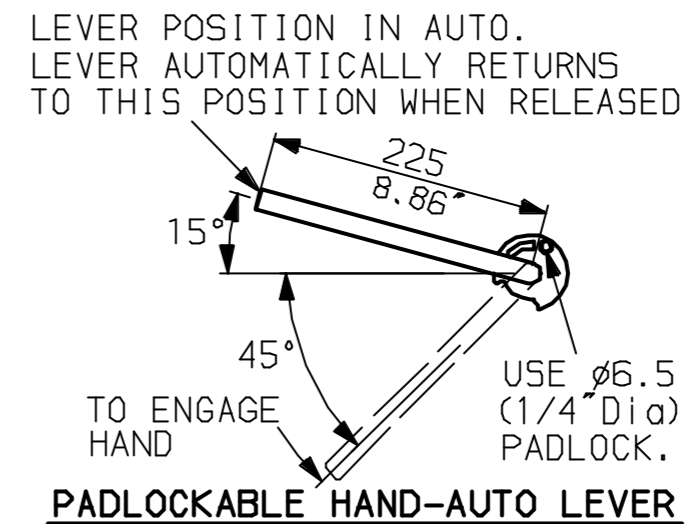
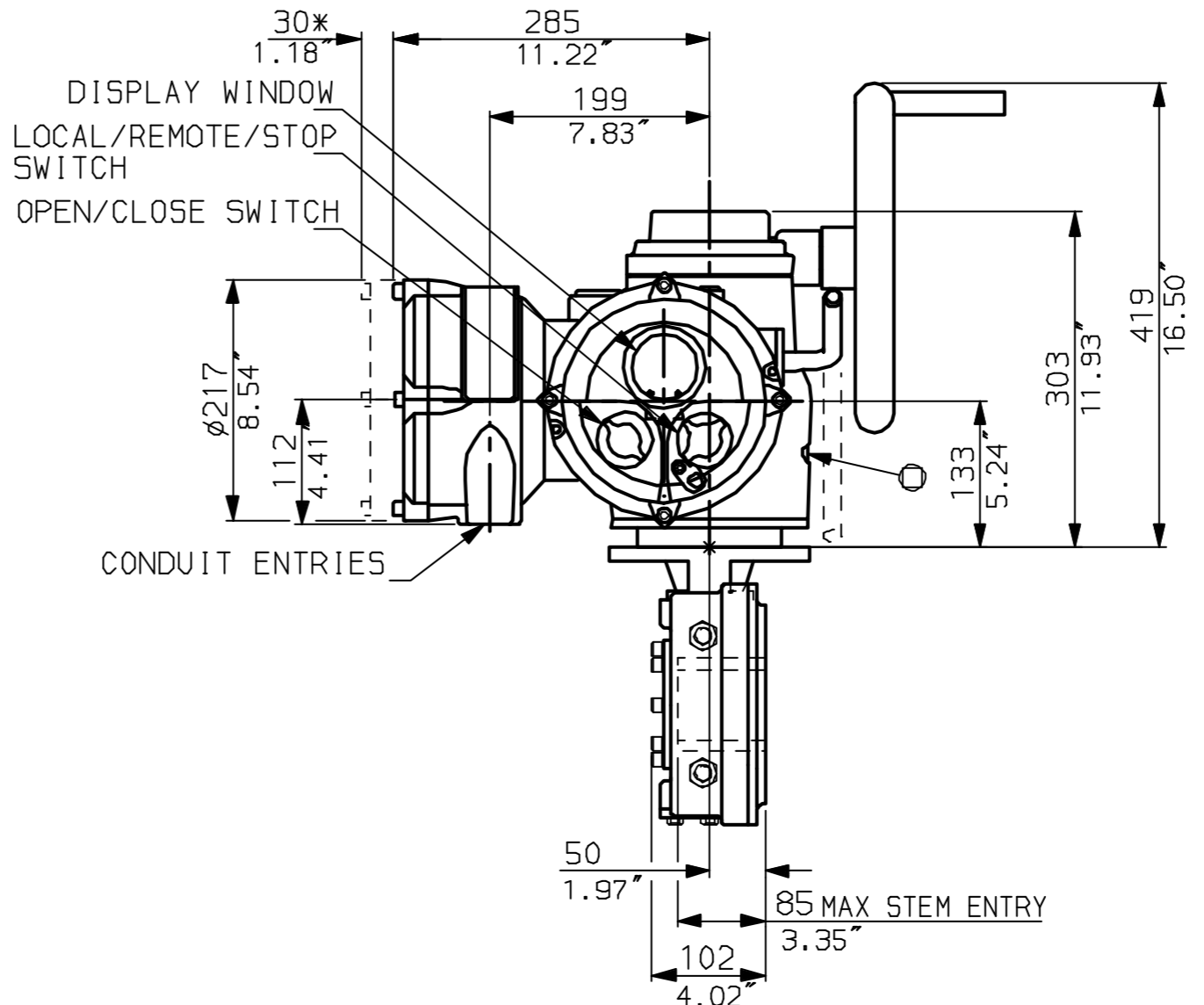
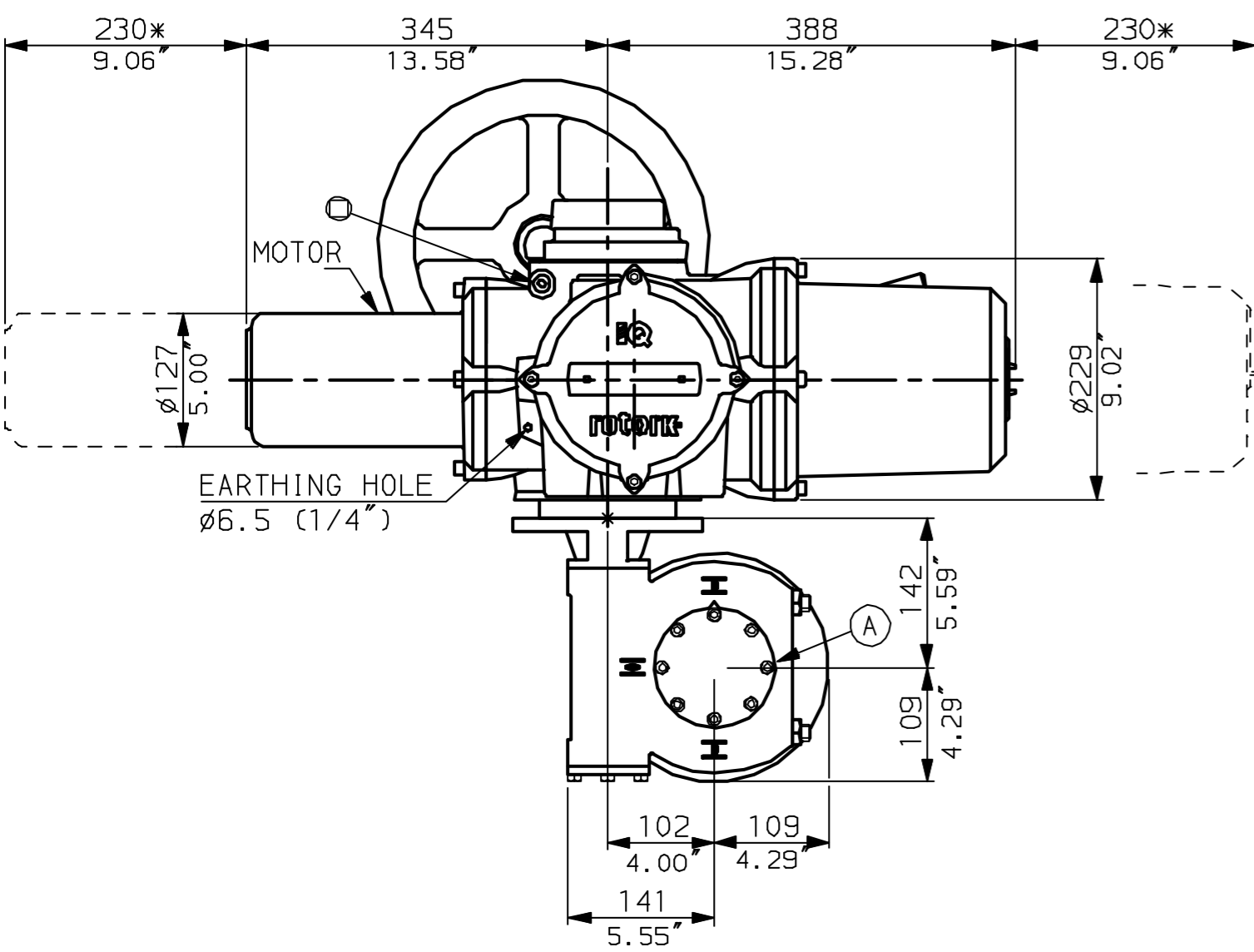
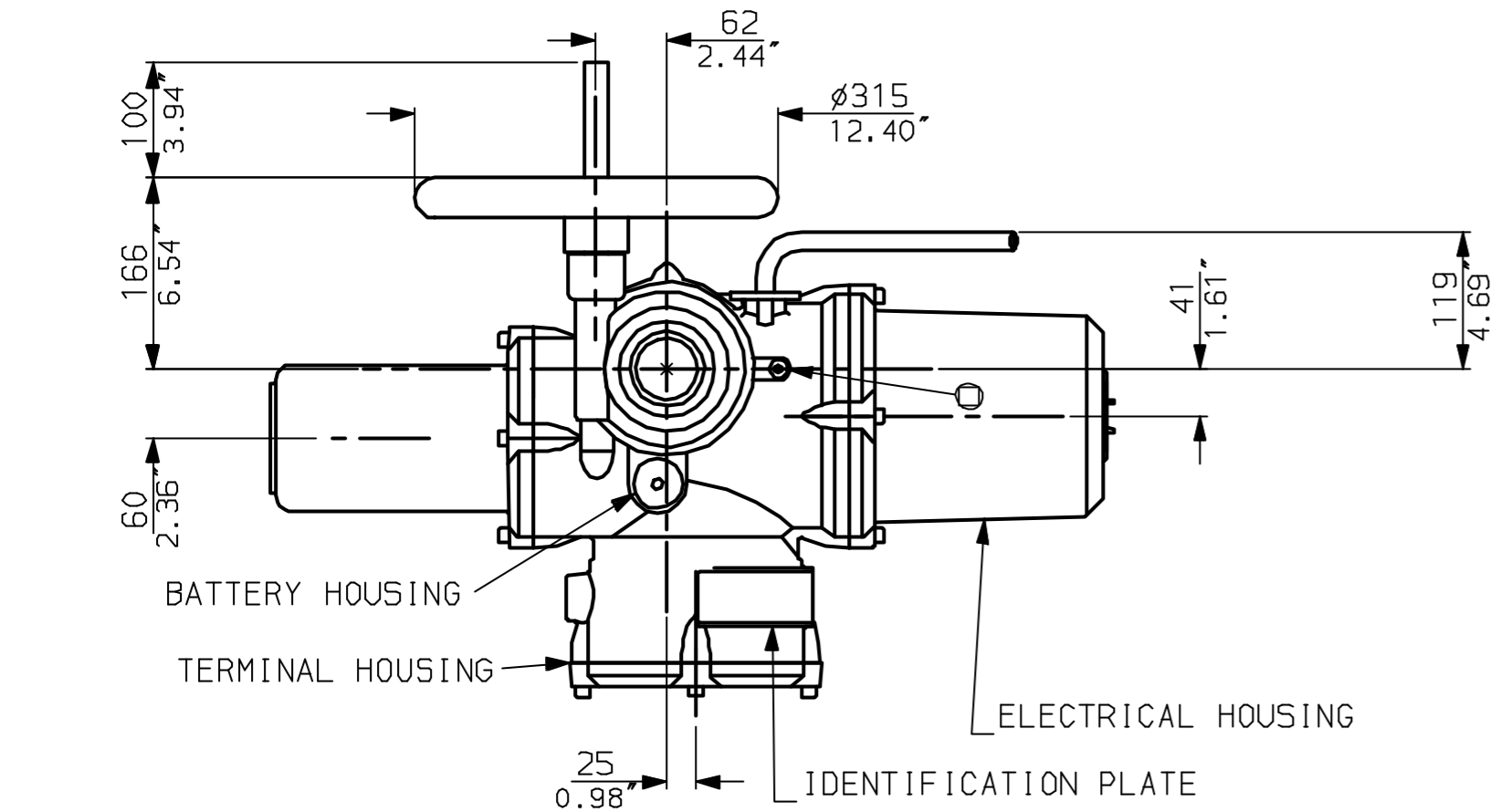

NOTES:  
 \*DIMENSIONS WITH '\*' INDICATE COVER REMOVAL ALLOWANCE  
 NETT WEIGHT = 74kg (163lbs)  
 ○ = OIL FILLER/DRAIN PLUG  
 THE INTERFACE PROVIDED FOR MOUNTING THE ACTUATOR OR SECOND STAGE GEARBOX ONTO THE VALVE SHOULD CONFORM TO GOOD ENGINEERING PRACTICES, ENSURING ADEQUATELY TOLERANCED LIMITS FOR PARALLELISM, PERPENDICULARITY AND CONCENTRICITY.

**CONDUIT ENTRIES** (N.T.S)

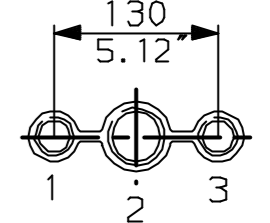

Nos.1 & 3 TAPPED 1" NPT  
 No.2 TAPPED 1 1/2" NPT  
 STD ALTERNATIVES IF SPECIFIED  
 2 X M25, 1 X M40  
 2 X PG16, 1 X PG29

N.B. KEYWAY POS. CAN BE MOVED 90 OR 180° BY REMOVING 8 SCREWS MARKED (A) AND ROTATING OUTPUT SLEEVE.

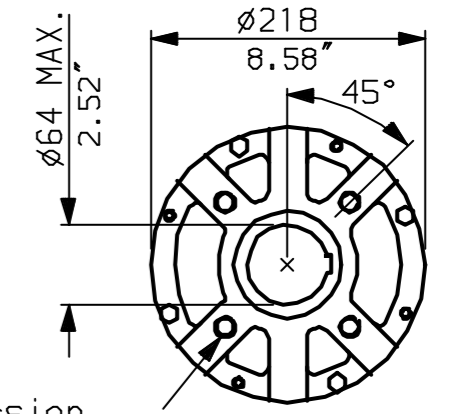

"F" version  
 4 HOLES TAPPED M16 x 16 DP  
 EQUI-SPACED AS SHOWN ON A  
 140 PCD (150 5211-F14).

"FA" version  
 4 HOLES TAPPED 5/8" UNC x 0.63" dp  
 EQUI-SPACED AS SHOWN ON A  
 5.5" PCD (MSS 5P101-FA14).



Rotork Controls Ltd.  
 Bath England, BA1 3JQ.  
 (Phone 01225-733200)  
 Rotork Controls Inc.  
 Rochester, NY 14624  
 (Phone 585-328-1550)

Title IQ20, 25 (+IQS20), SHW, IW4,		
STANDARD DIMENSIONAL DATA		
Drawn CAD	Checked PRE	Ref Data Sheet
Date April 04	Job No IQ25HW_IW4	

01	First Issue.
Scale	1:6 THIRD ANGLE PROJECTION
Drawing Number	IQ25HW_IW4

1 | 2 | 3 | 4 | 5 | 6 | 7 | 8 | 9 | 10