

PUB-IS15-F40

THIRD ANGLE PROJECTION
DO NOT SCALE

EXECCO LTD © 2011

ISSUE	ALTERATIONS
A	ORIGINAL ISSUE

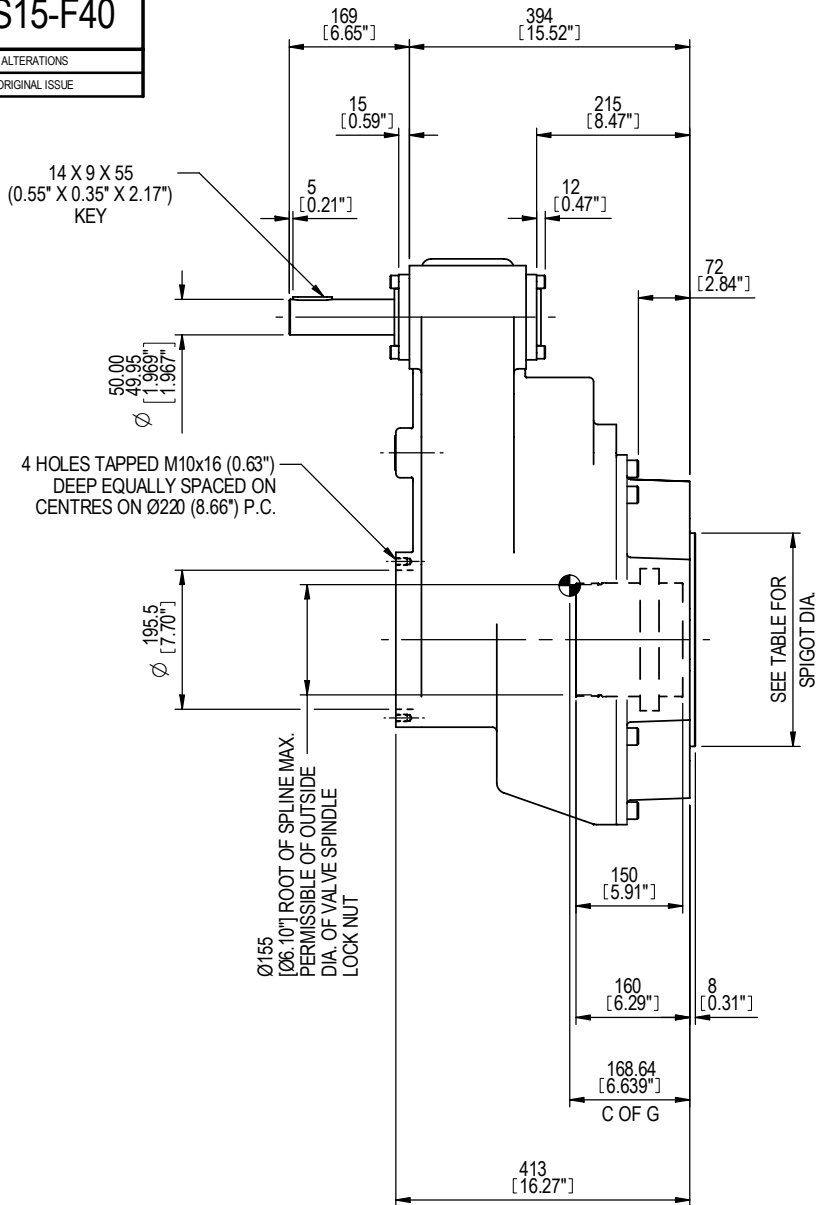

SEE TABLE FOR
HOLE DETAILS

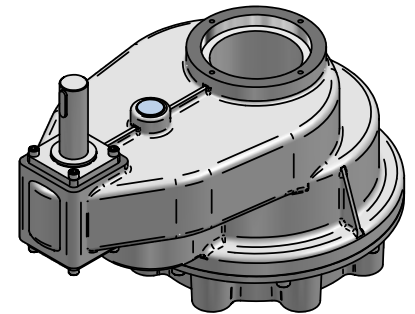
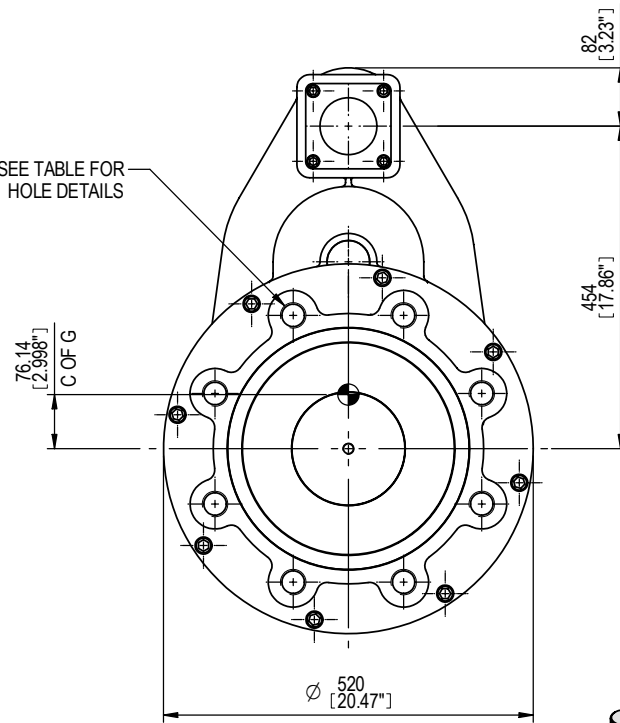

NOTES:

1. ALL DIMENSIONS IN MM

ROTORK GEARS

REGINA HOUSE
RING ROAD
BRAMLEY
LEEDS
WEST YORKSHIRE

MATERIAL:-

PROJECT:- IS15 SPUR GEARBOX. 10, 12 & 15;1 RATIOS. MANUAL INPUT. F40 / FA40 OUTPUT.

MAX. RATED MANUAL THRUST
1112 KN

MAX. ACME THREAD
4.5/8"

MAX BORE SQUARE KEY	
STD	BORE KEY
BS4235	-
BS46	4.250" 1.1/4"SQ
ANSI B17.1	4.500" 1"SQ

MAX BORE RECTANGULAR KEY		
STD	BORE	KEY
BS4235	121.0	32 x 18
BS46	4.625"	1.1/4" x 7/8"
ANSI B17.1	4.625"	1.1/4" x 7/8"

BASE PLATE DETAILS

	SPIGOT DIA.	HOLE DETAILS (22.5° OFF CENTRES)
F40	Ø299.95 - 0.05 (Ø11.809" - 0.002")	8 HOLES M36x45 (1.77") DEEP ON Ø406.0 (Ø15.98") P.C.
FA40	Ø228.60 - 0.15 (Ø9.000" - 0.006")	8 HOLES 1.25"UNCx45 (1.77") DEEP ON Ø406.0 (Ø15.98") P.C.

WEIGHT: 289.05kg

DRAWN:- N.RAYNER 31/05/2011
CHECKED:- C.FLESHER 23/06/2011

SCALE
1:10 (A4)

HEAT
TREATMENT

PROTECTIVE
TREATMENT
SUITABLY PROTECT
FOR STORAGE

OUTLINE DRAWING IS15

PUB-IS15-F40