

INPUT FLANGE DETAILS					
	FLANGE O/DIA. & THICKNESS	SHAFT DIA.	RECESS DIA.	HOLE DETAILS (OFF CENTRES)	KEY DETAILS
ISO F14	Ø175 (Ø6.89") x 15 (0.59")	Ø30.00 -0.05 (Ø1.181" -0.002")	Ø100.05 +0.05 (Ø3.939" +0.002")	4 HOLES Ø16.5 (Ø0.65") ON Ø140.0 (Ø5.51") P.C.	8x7x55 (0.31"x0.28"x2.17")
FA14	Ø175 (Ø6.89") x 15 (0.59")	Ø30.00 -0.05 (Ø1.181" -0.002")	Ø95.27 +0.05 (Ø3.751" +0.002")	4 HOLES Ø16.5 (Ø0.65") ON Ø140.0 (Ø5.51") P.C.	8x7x55 (0.31"x0.28"x2.17")
ISO F16	Ø210 (Ø8.27") x 20 (0.79")	Ø40.00 -0.05 (Ø1.575" -0.002")	Ø130.05 +0.05 (Ø5.120" +0.002")	4 HOLES Ø20.5 (Ø0.81") ON Ø165.0 (Ø6.50") P.C.	12x8x55 (0.47"x0.31"x2.17")
FA16	Ø210 (Ø8.27") x 20 (0.79")	Ø40.00 -0.05 (Ø1.575" -0.002")	Ø126.92 +0.05 (Ø4.997" +0.002")	4 HOLES Ø20.5 (Ø0.81") ON Ø165.0 (Ø6.50") P.C.	12x8x55 (0.47"x0.31"x2.17")
ISO F25	Ø300 (Ø11.81") x 20 (0.79")	Ø50.00 -0.05 (Ø1.969" -0.002")	Ø200.10 +0.10 (Ø7.878" +0.004")	8 HOLES Ø16.5 (Ø0.65") ON Ø254.0 (Ø10.00") P.C.	14x9x55 (0.55"x0.35"x2.17")
FA25	Ø300 (Ø11.81") x 20 (0.79")	Ø50.00 -0.05 (Ø1.969" -0.002")	Ø152.37 +0.10 (Ø5.999" +0.004")	8 HOLES Ø16.5 (Ø0.65") ON Ø254.0 (Ø10.00") P.C.	14x9x55 (0.55"x0.35"x2.17")

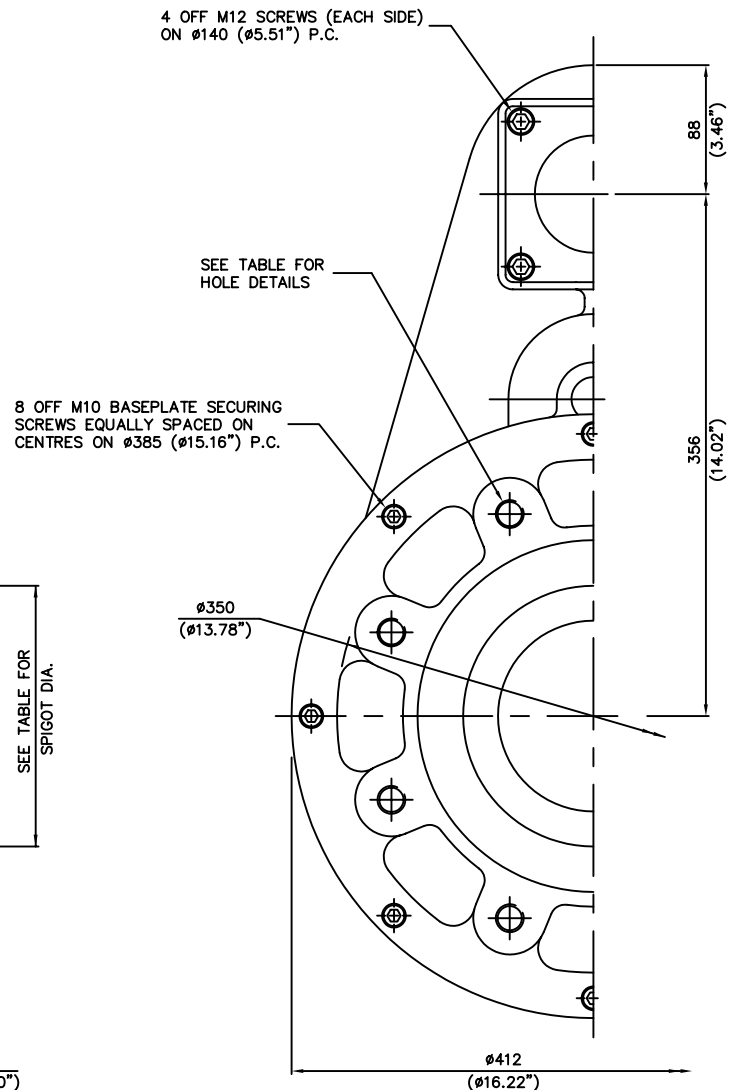
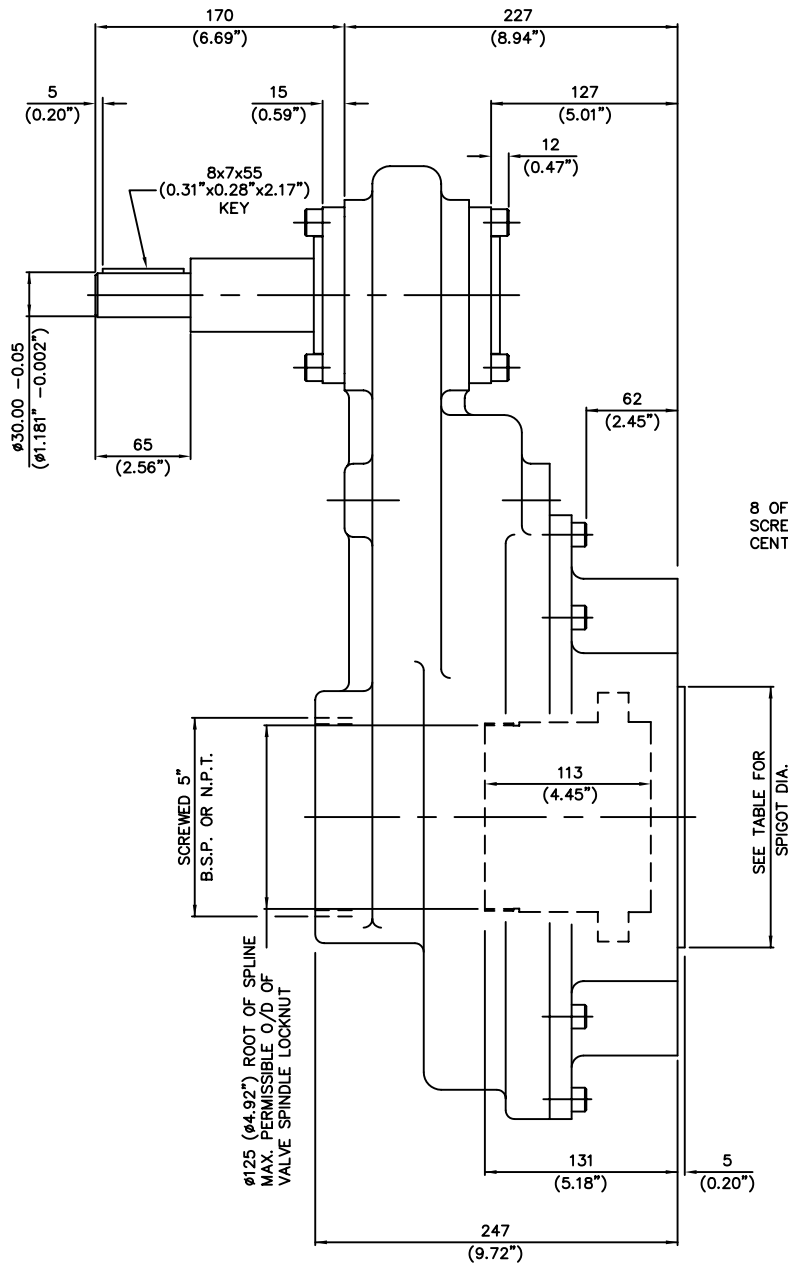

BASEPLATE DETAILS		
	SPIGOT DIA.	HOLE DETAILS (22.5" OFF CENTRES)
ISO F30	Ø229.95 -0.05 (Ø9.053" -0.002")	8 HOLES M20x25 (0.98") DEEP ON Ø298.0 (Ø11.73") P.C.
FA30	Ø177.70 -0.05 (Ø6.996" -0.002")	8 HOLES 3/4"UNCx25 (0.98") DEEP ON Ø298.5 (Ø11.75") P.C.

1	CN1171 D.S. 12-4-00
A	ORIGINAL ISSUE
ISSUE	ALTERATIONS

**rotork
gears**

NOMINAL RATIO	4:1	6:1	8:1	10:1	12:1	15:1		
EXACT RATIO	4.04:1	6.11:1	7.81:1	10.17:1	12.11:1	14.66:1	DRAWN:-	S.W. 10.9.96
FACTOR (MECH. ADVANTAGE)	3.633	5.500	7.025	9.156	10.900	13.194	CHECKED:-	

EXECCO LTD © 1996

OUTLINE DETAILS OF IS11
ISO & USA STANDARD

PUB\IS11CD