

INPUT FLANGE DETAILS					
	FLANGE O/DIA. & THICKNESS	SHAFT DIA.	RECESS DIA.	HOLE DETAILS (45° OFF CENTRES)	KEY DETAILS
ISO F10	Ø125 (Ø4.92") x 10 (0.39")	Ø20.00 -0.05 (Ø0.787" -0.002")	Ø70.05 +0.05 (Ø2.758" +0.002")	4 HOLES Ø10.5 (Ø0.41") ON Ø102.0 (Ø4.02") P.C.	6x6x40 (0.24"x0.24"x1.57")
FA10	Ø125 (Ø4.92") x 10 (0.39")	Ø20.00 -0.05 (Ø0.787" -0.002")	Ø58.75 +0.05 (Ø2.313" +0.002")	4 HOLES Ø10.5 (Ø0.41") ON Ø102.0 (Ø4.02") P.C.	6x6x40 (0.24"x0.24"x1.57")
ISO F14	Ø175 (Ø6.89") x 15 (0.59")	Ø30.00 -0.05 (Ø1.181" -0.002")	Ø100.05 +0.05 (Ø3.939" +0.002")	4 HOLES Ø16.5 (Ø0.65") ON Ø140.0 (Ø5.51") P.C.	8x7x40 (0.31"x0.28"x1.57")
FA14	Ø175 (Ø6.89") x 15 (0.59")	Ø30.00 -0.05 (Ø1.181" -0.002")	Ø95.27 +0.05 (Ø3.751" +0.002")	4 HOLES Ø16.5 (Ø0.65") ON Ø140.0 (Ø5.51") P.C.	8x7x40 (0.31"x0.28"x1.57")

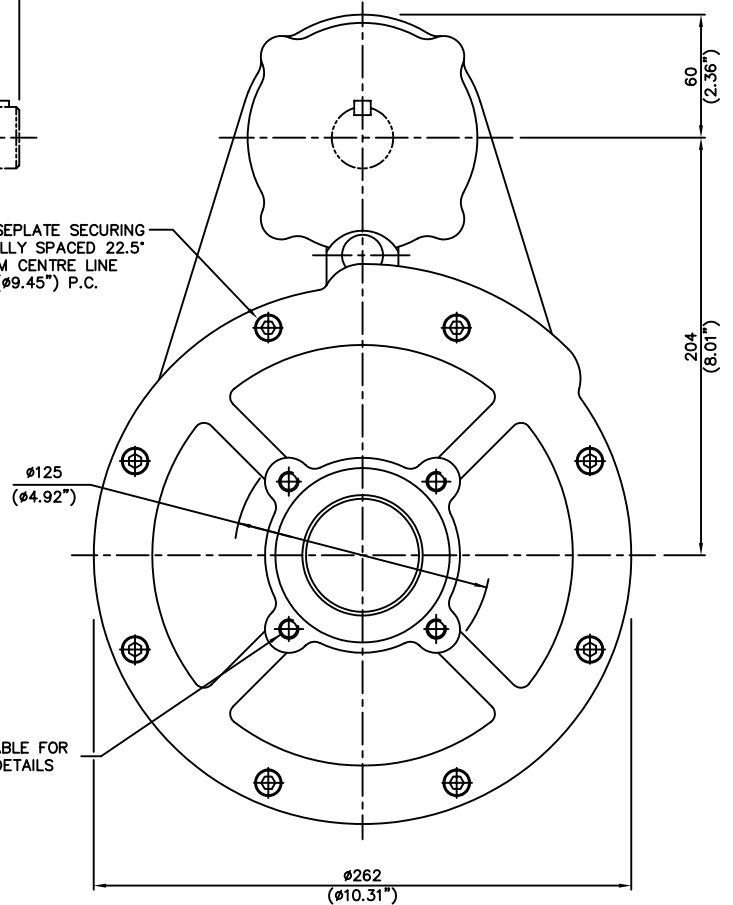
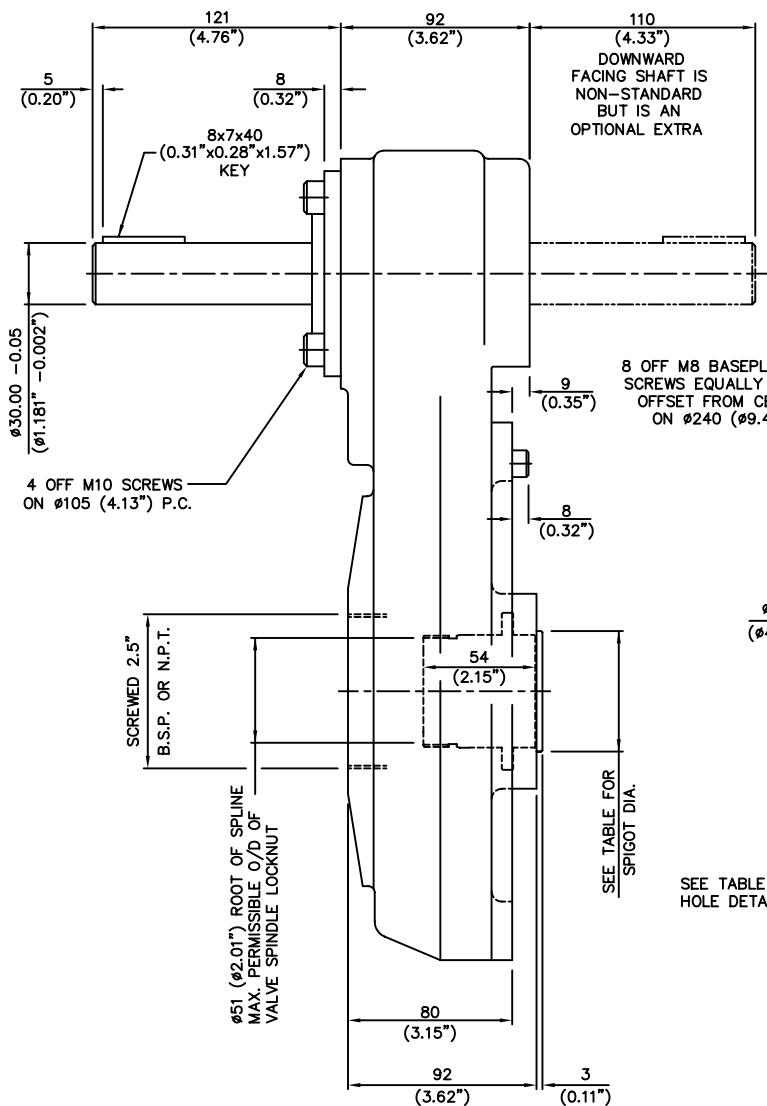

BASEPLATE DETAILS		
	SPIGOT DIA.	HOLE DETAILS (45° OFF CENTRES)
ISO F10	Ø69.95 -0.05 (Ø2.754" -0.002")	4 HOLES M10x15 (0.59") DEEP ON Ø102.0 (Ø4.02") P.C.
FA10	Ø58.70 -0.05 (Ø2.311" -0.002")	4 HOLES 3/8"UNCx15 (0.59") DEEP ON Ø101.6 (Ø4.00") P.C.

1	CN1413 D.S. 24.10.02
A	ORIGINAL ISSUE
ISSUE	ALTERATIONS

**rotork
gears**

NOMINAL RATIO	2:1	3:1	4:1	6:1
EXACT RATIO	2.12:1	3.00:1	4.10:1	6.00:1
FACTOR (MECH. ADVANTAGE)	1.90	2.70	3.69	5.40

DRAWN: -	S.W.	10.9.96	SCALE
CHECKED: -			1:1

EXECCO LTD © 1996

OUTLINE DETAILS OF IS4
ISO & USA STANDARD

PUB\IS4CD