

1	2		3		4		5		6			7		8	
INPUT FLANGE DETAILS							MOUNTING HOLES - BOLT CIRCLE (OFF CENTRES)								
INPUT FLANGE	FLANGE O/DIA. + THICKNESS	SHAFT DIA.	RECESS DIA.	RECESS DEPTH	HOLE DETAILS (45° OFF CENTRES)	KEY DETAILS	ISO 5211 / MSS SP-101 MOUNTING OPTION	HOLE DETAILS (45° OFF CENTRES)	STANDARD	MIN BORE	SQ KEY MAX BORE	SQ KEY SIZE	RECT. KEY MAX BORE	RECT. KEY SIZE	SQ BORE MAX
ISO F14	Ø175 x 15 (Ø6.89" x 0.59")	Ø20.00-0.05 (Ø0.787"-0.002")	Ø100.05+0.15 (Ø3.939"+0.006")	5 (0.20")	4 x Ø16.5 ON Ø140.0 P.C. (4 x Ø0.65" ON Ø5.51" P.C.)	6x6x40 (0.24"x0.24"x1.57")	ISO F14*	4 x M16 x 16 (0.63") DEEP ON Ø140.0 (Ø5.51") P.C.	BS4235	-	-	-	64.0	18 x 11	□ 51.0 (2.01")
FA14							BS46		-	2.25"	5/8" SQ.	2.50"	5/8" x 7/16"		
			Ø95.25+0.15 (Ø3.750"+0.006")				FA14*	4 x 5/8" UNC x 16 (0.63") DEEP ON Ø139.7 (Ø5.50") P.C.	ANSI B17.1	-	2.25"	1/2" SQ.	2.50"	5/8" x 7/16"	
									DIN 6885	-	-	-	64.0	18 x 11	

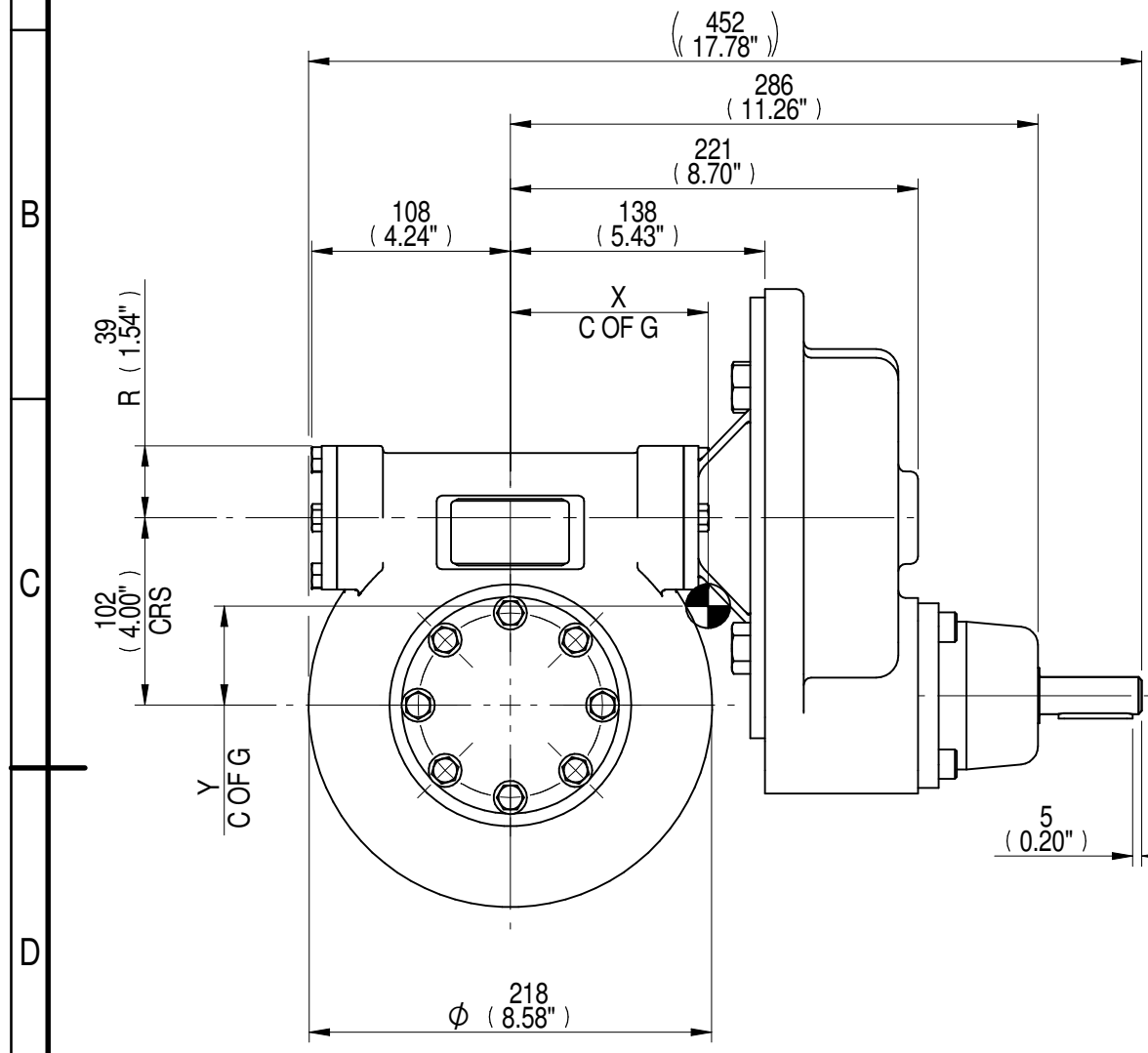

VIEW SHOWING MANUAL OPERATED UNIT

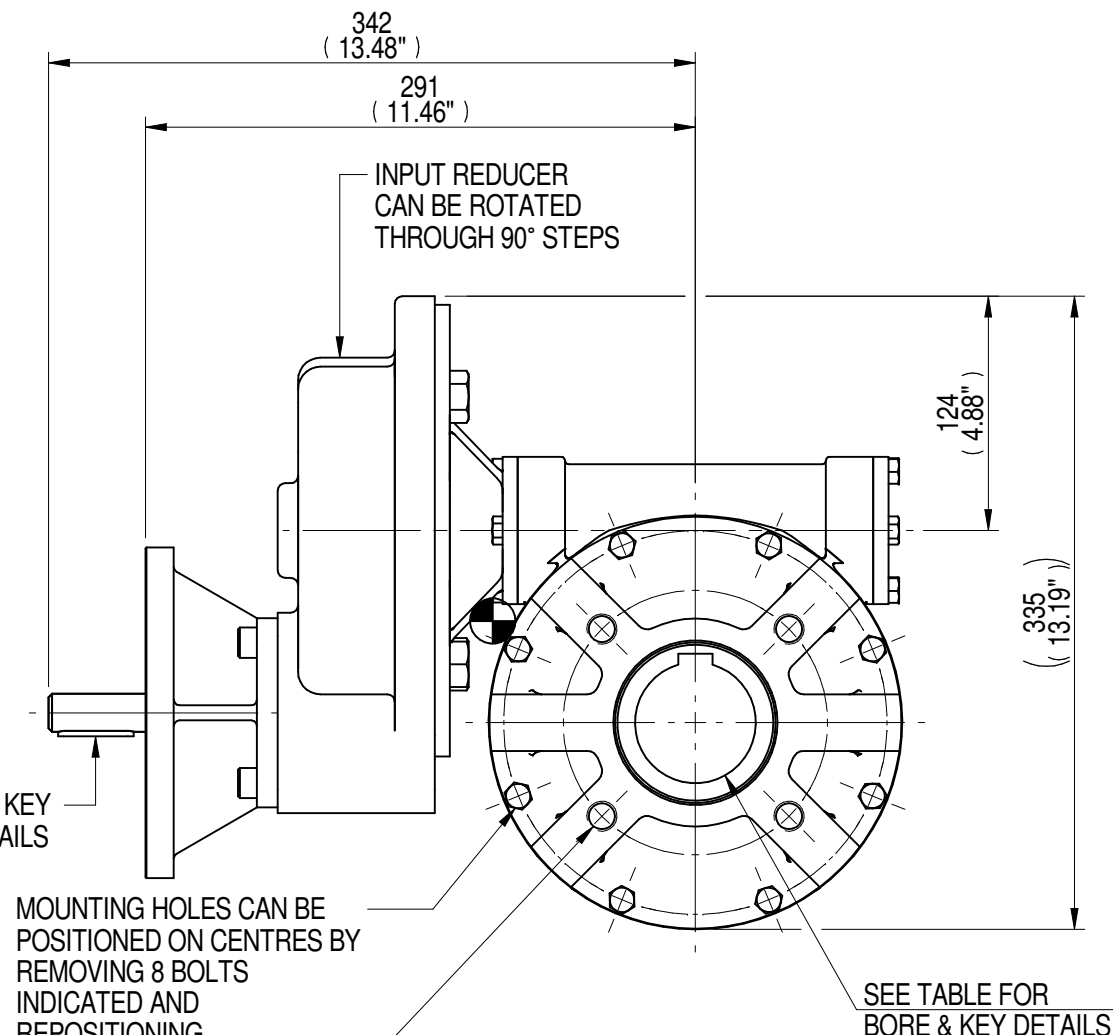
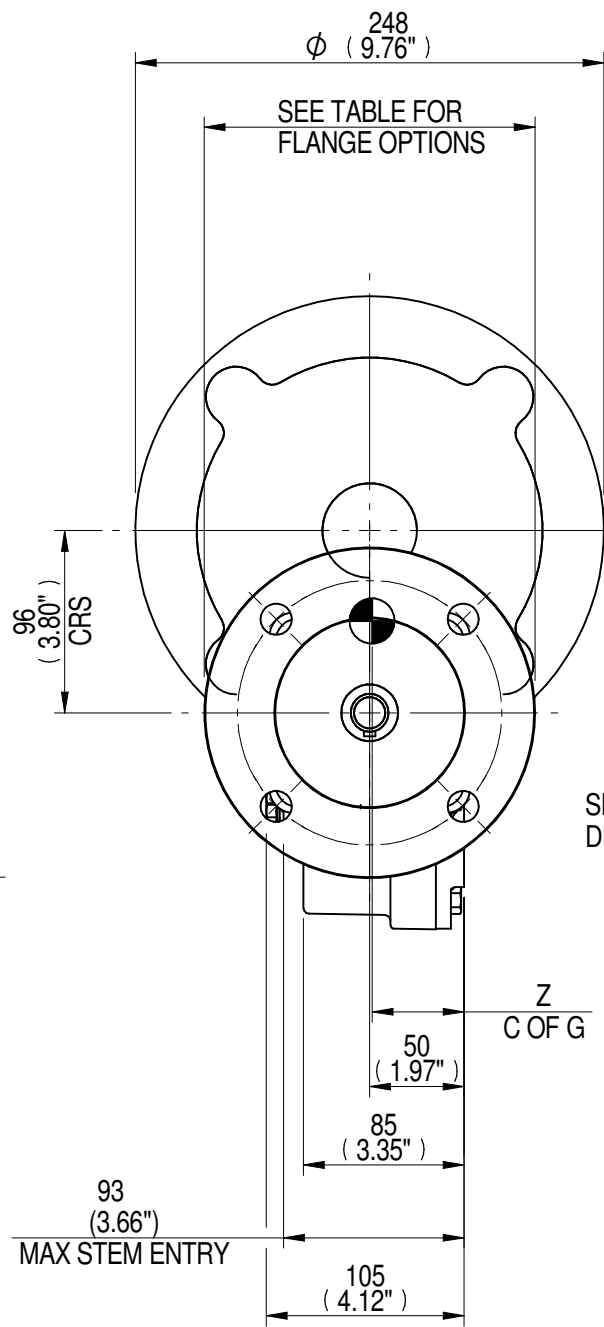

VIEW SHOWING MOTORISED UNIT

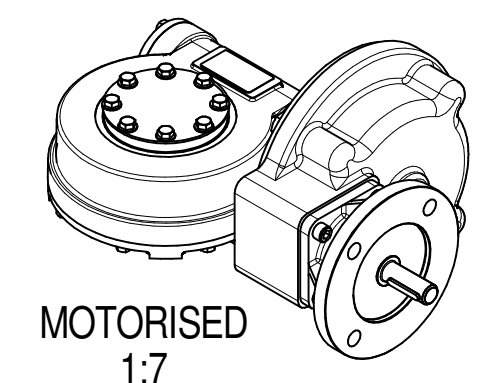
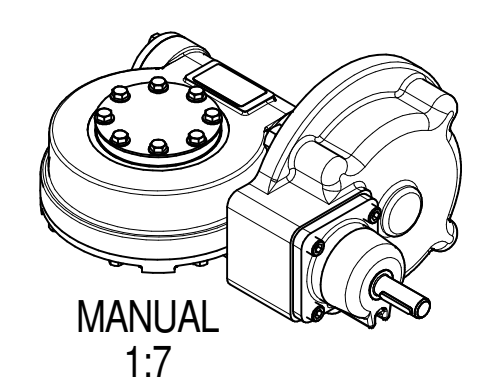

PLAN VIEW OF GEARBOX IN CLOSED POSITION SHOWING STANDARD KEYWAY POSITIONS. ALTERNATIVES AVAILABLE ON REQUEST

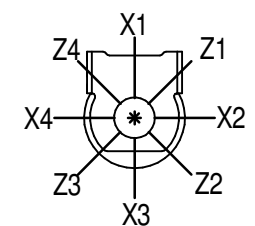

NOTES:
 1. * THREAD DEPTH DOES NOT MATCH ISO STANDARD
 2. CENTRE OF GRAVITY POSITION IS INDICATIVE FOR STANDARD BUILD WHEN IN POSITION SHOWN

420	132	43	1966	15	108	54	49
350	110	43	1966	18	108	53	49
240	86	44	1966	23	107	54	49
200	71	43	1898	27	107	53	49
RATIO	M.A. ± 10%	WEIGHT (Kg)	MAX OUTPUT (Nm)	MAX INPUT (Nm)	X	Y	Z
DESCRIPTION			TORQUE		CENTRE OF GRAVITY		

AS PART OF CONTINUOUS PRODUCT DEVELOPMENT, ALL DETAILS SUBJECT TO CHANGE WITHOUT PRIOR NOTICE. FOR UP TO DATE DETAILS PLEASE VISIT www.rotork.com

	This drawing is confidential and is the property of Rotork Gears and must not be reproduced either wholly or partly. All rights in respect of patents, designs and copyrights are reserved. ©2015	Document Type PUBLICITY Dimensions in mm	Title MTW4 MULTI-TURN GEARBOX, 200/240/350/420:1 MANUAL, F14/FA14 INPUT, F14/FA14 OUTPUT
	www.rotork.com		Drawing Number PUB-MTW4IRL-F14-F14