

1	2		3		4		5		6			7		8	
INPUT FLANGE DETAILS							MOUNTING HOLES - BOLT CIRCLE (OFF CENTRES)								
INPUT FLANGE	FLANGE O/DIA. + THICKNESS	SHAFT DIA.	RECESS DIA.	RECESS DEPTH	HOLE DETAILS (45° OFF CENTRES)	KEY DETAILS	ISO 5211 / MSS SP-101 MOUNTING OPTION	HOLE DETAILS (45° OFF CENTRES)	STANDARD	MIN BORE	SQ KEY MAX BORE	SQ KEY SIZE	RECT. KEY MAX BORE	RECT. KEY SIZE	SQ BORE MAX
ISO F14	Ø181 x 16 (Ø7.13" x 0.63")	Ø25.00-0.05 (Ø0.984"-0.002")	Ø100.05+0.15 (Ø3.939"+0.006")	5 (0.20")	4 x Ø16.5 ON Ø140.0 P.C. (4 x Ø0.65" ON Ø5.51" P.C.)	8x7x40 (0.31"x0.28"x1.57")	ISO F16*	4 x M20 x 16 (0.63") DEEP ON Ø165.0 (Ø6.50") P.C.	BS4235	-	-	-	76.0	22 x 14	□ 62.0 (2.44")
FA14			BS46						-	2.75"	3/4" SQ.	3.00"	3/4" x 1/2"		
	ANSI B17.1	-	2.75"	5/8" SQ.	3.00"	3/4" x 1/2"									
			Ø95.25+0.15 (Ø3.750"+0.006")				FA16*	4 x 3/4" UNC x 16 (0.63") DEEP ON Ø165.0 (Ø6.50") P.C.	DIN 6885	-	-	-	76.0	22 x 14	

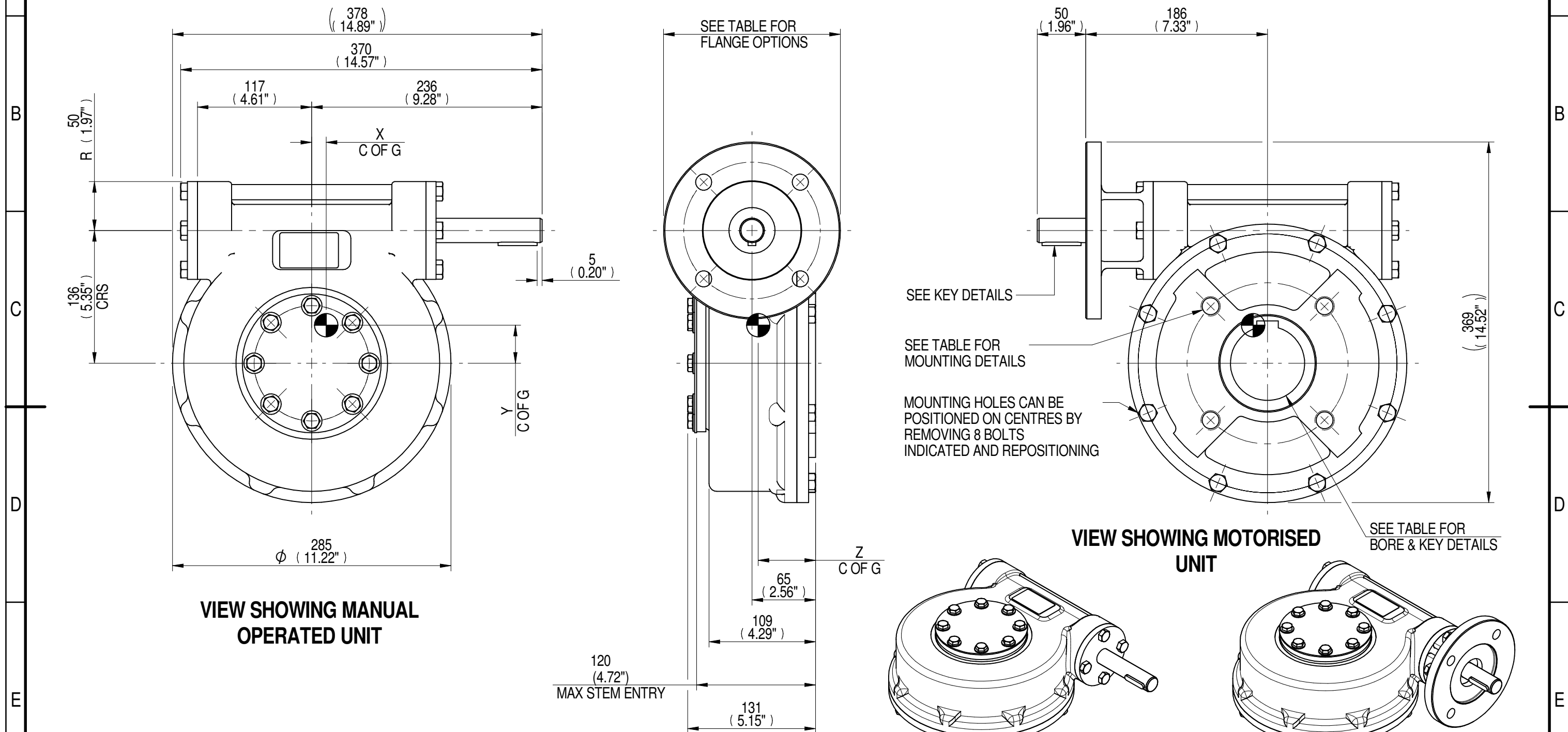

PLAN VIEW OF GEARBOX IN CLOSED POSITION SHOWING STANDARD KEYWAY POSITIONS. ALTERNATIVES AVAILABLE ON REQUEST



NOTES:
 1. * THREAD DEPTH DOES NOT MATCH ISO STANDARD
 2. CENTRE OF GRAVITY POSITION IS INDICATIVE FOR STANDARD BUILD WHEN IN POSITION SHOWN

70	23	39	2847	124	16	40	58
40	17	41	2847	167	16	39	59
RATIO	M.A. ± 10%	WEIGHT (Kg)	MAX OUTPUT (Nm)	MAX INPUT (Nm)	X	Y	Z
DESCRIPTION			TORQUE		CENTRE OF GRAVITY		

AS PART OF CONTINUOUS PRODUCT DEVELOPMENT, ALL DETAILS SUBJECT TO CHANGE WITHOUT PRIOR NOTICE. FOR UP TO DATE DETAILS PLEASE VISIT www.rotork.com

rotork Gears
 LEEDS - UK
www.rotork.com

This drawing is confidential and is the property of Rotork Gears and must not be reproduced either wholly or partly. All rights in respect of patents, designs and copyrights are reserved. ©2015

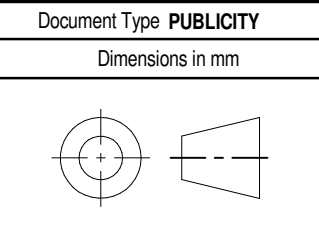

Title MTW5 MULTI-TURN GEARBOX, 40/70:1 MANUAL, F14/FA14 INPUT, F16/FA16 OUTPUT		Iss. 01
Drawing Number PUB-MTW5-F14-F16		
Sheet 1 of 1	Size A3	