

INPUT FLANGE DETAILS							MOUNTING HOLES - BOLT CIRCLE (OFF CENTRES)								
INPUT FLANGE	FLANGE O/DIA. + THICKNESS	SHAFT DIA.	RECESS DIA.	RECESS DEPTH	HOLE DETAILS (OFF CENTRES)	KEY DETAILS	ISO 5211 / MSS SP-101 MOUNTING OPTION	HOLE DETAILS (45° OFF CENTRES)	STANDARD	MIN BORE	SQ KEY MAX BORE	SQ KEY SIZE	RECT. KEY MAX BORE	RECT. KEY SIZE	SQ BORE MAX
ISO F14	Ø175 x 15 (Ø8.89" x 0.59")	Ø20.00-0.05 (Ø0.787"-0.002")	Ø100.05+0.15 (Ø3.939"+0.006")	5 (0.20")	4 x Ø16.5 ON Ø140.0 P.C. (4 x Ø0.65" ON Ø5.51" P.C.)	6x6x40 (0.24"x0.24"x1.57")	ISO F16*	4 x M20 x 16 (0.63") DEEP ON Ø165.0 (Ø6.50") P.C.	BS4235	-	-	-	102	28 x 16	□ 83.3 (3.28")
FA14			FA16*				4 x 3/4" UNC x 16 (0.63") DEEP ON Ø165.0 (Ø6.50") P.C.		ANSI B17.1	-	3.625"	1" SQ.	3.75"	1" x 3/4"	
		Ø95.25+0.15 (Ø3.750"+0.006")						DIN 6885	-	-	-	102	28 x 16		

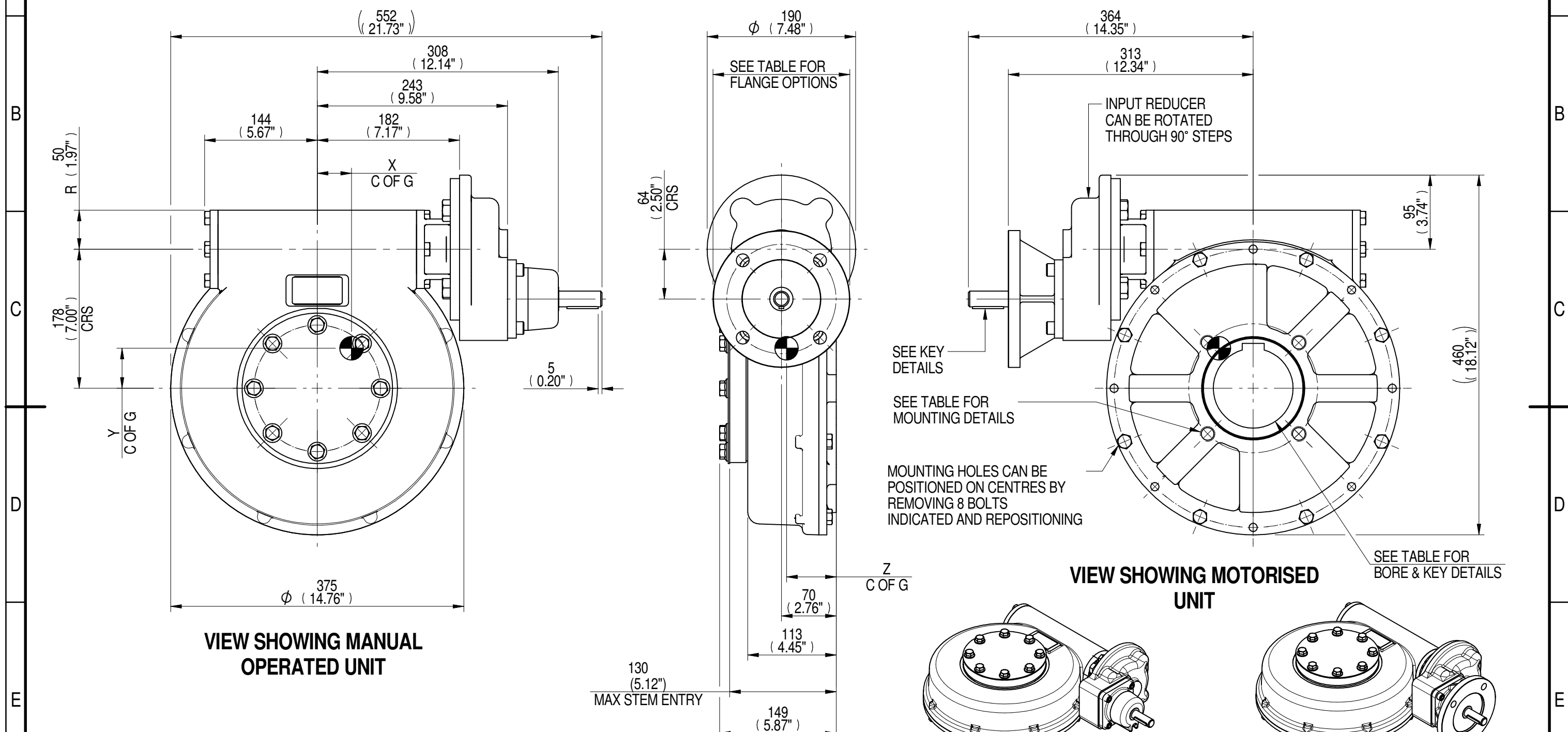

PLAN VIEW OF GEARBOX IN CLOSED POSITION SHOWING STANDARD KEYWAY POSITIONS. ALTERNATIVES AVAILABLE ON REQUEST

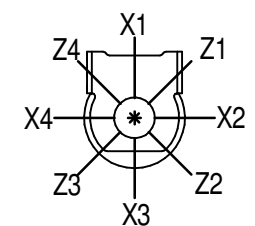

NOTES:
 1. * THREAD DEPTH DOES NOT MATCH ISO STANDARD
 2. CENTRE OF GRAVITY POSITION IS INDICATIVE FOR STANDARD BUILD WHEN IN POSITION SHOWN

280	88	74	8270	94	44	52	64
210	66	73	7728	117	44	51	64
140	44	73	7728	176	43	51	64
RATIO	M.A. ± 10%	WEIGHT (Kg)	MAX OUTPUT (Nm)	MAX INPUT (Nm)	X	Y	Z
DESCRIPTION			TORQUE		CENTRE OF GRAVITY		

AS PART OF CONTINUOUS PRODUCT DEVELOPMENT, ALL DETAILS SUBJECT TO CHANGE WITHOUT PRIOR NOTICE. FOR UP TO DATE DETAILS PLEASE VISIT www.rotork.com

rotork Gears
 LEEDS - UK
www.rotork.com

This drawing is confidential and is the property of Rotork Gears and must not be reproduced either wholly or partly. All rights in respect of patents, designs and copyrights are reserved. ©2015

Document Type **PUBLICITY**
 Dimensions in mm

Title
MTW6 MULTI-TURN GEARBOX, 140/210/280:1 MANUAL, F14/FA14 INPUT, F16/FA16 OUTPUT

Drawing Number
PUB-MTW6IRS-F14-F16

Sheet 1 of 1 Size A3