

1	2		3		4		5		6			7		8	
INPUT FLANGE DETAILS							MOUNTING HOLES - BOLT CIRCLE (OFF CENTRES)								
INPUT FLANGE	FLANGE O/DIA. + THICKNESS	SHAFT DIA.	RECESS DIA.	RECESS DEPTH	HOLE DETAILS (45° OFF CENTRES)	KEY DETAILS	ISO 5211 / MSS SP-101 MOUNTING OPTION	HOLE DETAILS (45° OFF CENTRES)	STANDARD	MIN BORE	SQ KEY MAX BORE	SQ KEY SIZE	RECT. KEY MAX BORE	RECT. KEY SIZE	SQ BORE MAX
ISOF16	Ø210 x 15 (Ø8.27" x 0.59")	Ø30.00-0.05 (Ø1.181"-0.002")	Ø130.05 + 0.15 (Ø5.120" + 0.006")	5 (0.20")	4 x Ø20.5 ON Ø165.0 P.C. (4 x Ø0.81" ON Ø6.50" P.C.)	8x7x40 (0.31"x0.28"x1.57")	ISO F16*	4 x M20 x 20 (0.79") DEEP ON Ø165.0 (Ø6.50") P.C.	BS4235	-	-	-	102	28 x 16	□ 83.3 (3.28")
FA16			BS46						-	3.625"	1" SQ.	3.75"	1" x 3/4"		
	ANSI B17.1	-	3.75"	7/8" SQ.	3.875"	1" x 3/4"									
	DIN 6885	-	-	-	102	28 x 16									

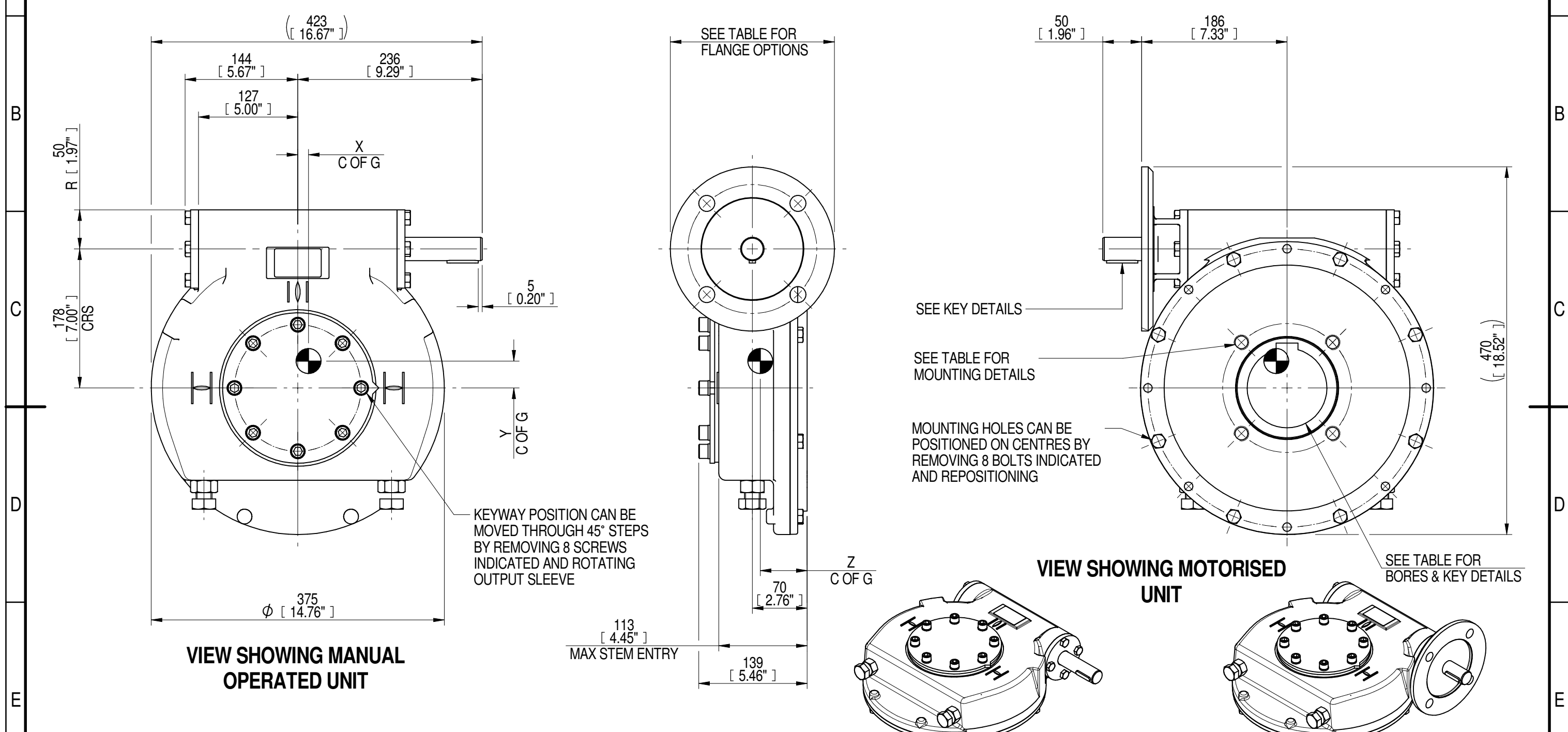

PLAN VIEW OF GEARBOX IN CLOSED POSITION SHOWING STANDARD KEYWAY POSITIONS. ALTERNATIVES AVAILABLE ON REQUEST

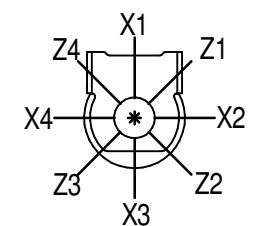

NOTES:
 1. * THREAD DEPTH DOES NOT MATCH ISO STANDARD
 2. CENTRE OF GRAVITY POSITION IS INDICATIVE FOR STANDARD BUILD WHEN IN POSITION SHOWN

70	18	23	61	8135	354	14	34	60
RATIO	TURNS TO CLOSE	M.A. ± 10%	WEIGHT (Kg)	MAX OUTPUT (Nm)	MAX INPUT (Nm)	X	Y	Z
DESCRIPTION			TORQUE			CENTRE OF GRAVITY		

AS PART OF CONTINUOUS PRODUCT DEVELOPMENT, ALL DETAILS SUBJECT TO CHANGE WITHOUT PRIOR NOTICE. FOR UP TO DATE DETAILS PLEASE VISIT www.rotork.com

rotork Gears
 LEEDS - UK
www.rotork.com

This drawing is confidential and is the property of Rotork Gears and must not be reproduced either wholly or partly. All rights in respect of patents, designs and copyrights are reserved. ©2016

Document Type **PUBLICITY**
 Dimensions in mm

Title
**IW/MOW6 QUARTER TURN GEARBOX, 70:1
 MANUAL F16/ FA16 INPUT: F16/ FA16
 OUTPUT**

Drawing Number
PUB-IW6FB-F16-F16

Sheet 1 of 1 Size A3

Iss. 01