

1	2		3		4		5		6			7		8	
INPUT FLANGE DETAILS							MOUNTING HOLES - BOLT CIRCLE (OFF CENTRES)								
INPUT FLANGE	FLANGE O/DIA. + THICKNESS	SHAFT DIA.	RECESS DIA.	RECESS DEPTH	HOLE DETAILS (45° OFF CENTRES)	KEY DETAILS	ISO 5211 / MSS SP-101 MOUNTING OPTION	HOLE DETAILS (22.5° OFF CENTRES)	STANDARD	MIN BORE	SQ KEY MAX BORE	SQ KEY SIZE	RECT. KEY MAX BORE	RECT. KEY SIZE	SQ BORE MAX
ISO F10	Ø125 x 16 (Ø4.92" x 0.63")	Ø20.00-0.05 (Ø0.787"-0.002")	Ø70.05+0.15 (Ø2.758"+0.006")	4 (0.16")	4 x Ø10.5 ON Ø102.0 P.C. (4 x Ø0.41" ON Ø4.02" P.C.)	6x6x40 (0.24"x0.24"x1.57")	ISO F25*	8 x M16 x 16 (0.63") DEEP ON Ø254.0 (Ø10.00") P.C.	BS4235	-	-	-	102	28 x 16	□ 83.3 (3.28")
FA10			BS46						-	3.625"	1" SQ.	3.75"	1" x 3/4"		
	ANSI B17.1	-	3.75"	7/8" SQ.	3.875"	1" x 3/4"	DIN 6885	-	-	-	102	28 x 16			

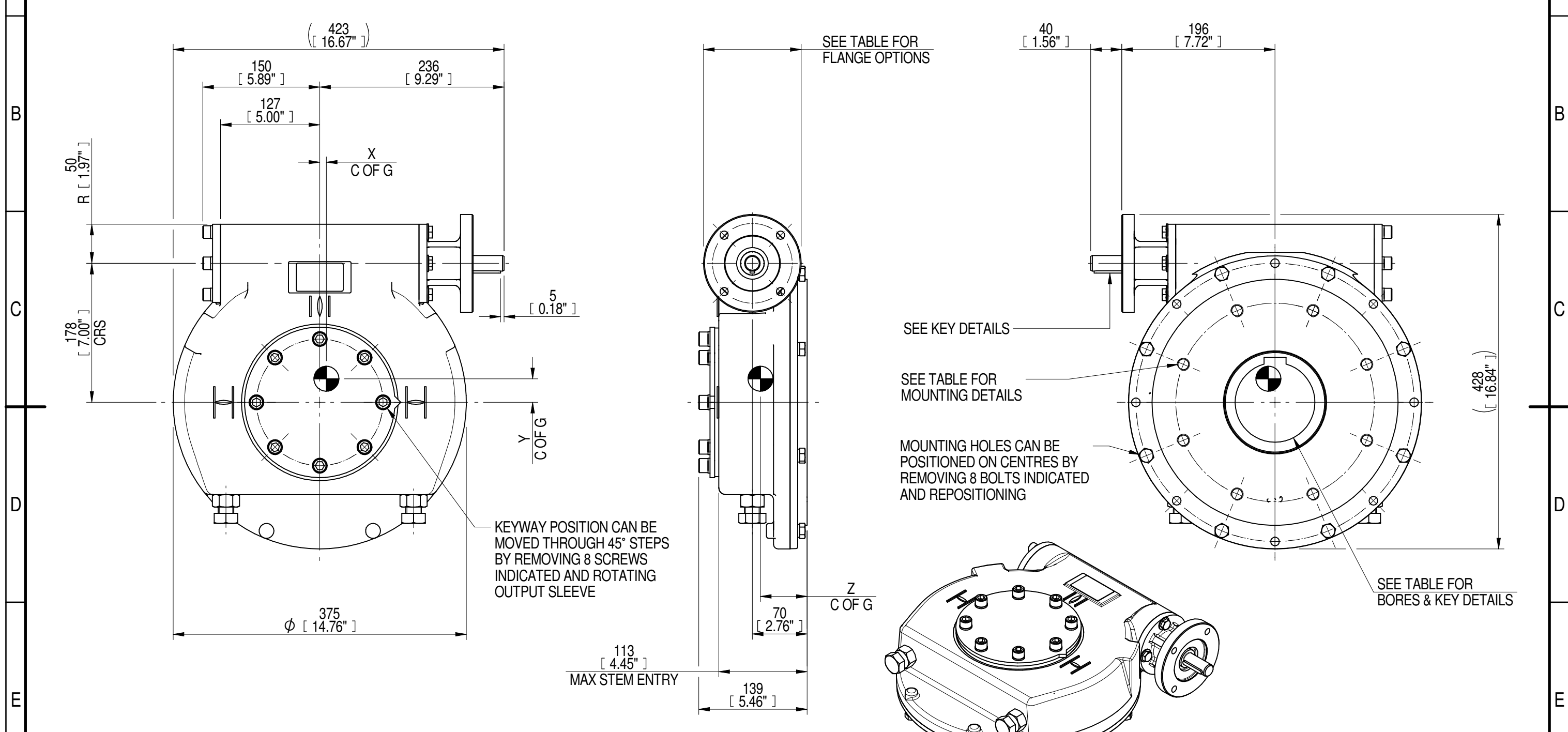

PLAN VIEW OF GEARBOX IN CLOSED POSITION SHOWING STANDARD KEYWAY POSITIONS. ALTERNATIVES AVAILABLE ON REQUEST



NOTES:  
 1. \* THREAD DEPTH DOES NOT MATCH ISO STANDARD  
 2. CENTRE OF GRAVITY POSITION IS INDICATIVE FOR STANDARD BUILD WHEN IN POSITION SHOWN

RATIO	TURNS TO CLOSE	M.A.±10%	WEIGHT (Kg)	MAX OUTPUT (Nm)	MAX INPUT (Nm)	X	Y	Z
70	18	23	59	9650	420	9	30	60
DESCRIPTION			TORQUE			CENTRE OF GRAVITY		

AS PART OF CONTINUOUS PRODUCT DEVELOPMENT, ALL DETAILS SUBJECT TO CHANGE WITHOUT PRIOR NOTICE. FOR UP TO DATE DETAILS PLEASE VISIT [www.rotork.com](http://www.rotork.com)

	Document Type <b>PUBLICITY</b>	Title <b>IW/MOW63 QUARTER TURN GEARBOX, 70:1 F10/ FA10 INPUT: F25/ FA25 OUTPUT</b>
	Dimensions in mm	
	Drawing Number <b>PUB-IW63FB-F10-F25</b>	Iss. 01
LEEDS - UK <a href="http://www.rotork.com">www.rotork.com</a>	Sheet 1 of 1	Size A3