

INPUT FLANGE DETAILS							MOUNTING HOLES - BOLT CIRCLE (OFF CENTRES)								
INPUT FLANGE	FLANGE O/DIA. + THICKNESS	SHAFT DIA.	RECESS DIA.	RECESS DEPTH	HOLE DETAILS (45° OFF CENTRES)	KEY DETAILS	ISO 5211 / MSS SP-101 MOUNTING OPTION	HOLE DETAILS (22.5° OFF CENTRES)	STANDARD	MIN BORE	SQ KEY MAX BORE	SQ KEY SIZE	RECT. KEY MAX BORE	RECT. KEY SIZE	SQ BORE MAX
ISO F14	Ø175 x 15 (Ø6.89" x 0.59")	Ø30.00-0.05 (Ø1.181"-0.002")	Ø100.05+0.15 (Ø3.939"+0.006")	5 (0.20")	4 x Ø16.5 ON Ø140.0 P.C. (4 x Ø0.65" ON Ø5.51" P.C.)	8x7x55 (0.31"x0.28"x2.17")	ISO F25*	8 x M16 x 24 (0.94") DEEP ON Ø254.0 (Ø10.00") P.C.	BS4235	-	-	-	136	36 x 20	□ 108.8 (4.28")
FA14			FA25*				8 x 5/8" UNC x 24 (0.94") DEEP ON Ø254.0 (Ø10.00") P.C.		ANSI B17.1	-	4.875"	1.1/4" SQ.	5.25"	1.1/4" x 7/8"	
		Ø95.25+0.15 (Ø3.750"+0.006")					DIN 6885	-	-	-	-	136	36 x 20		

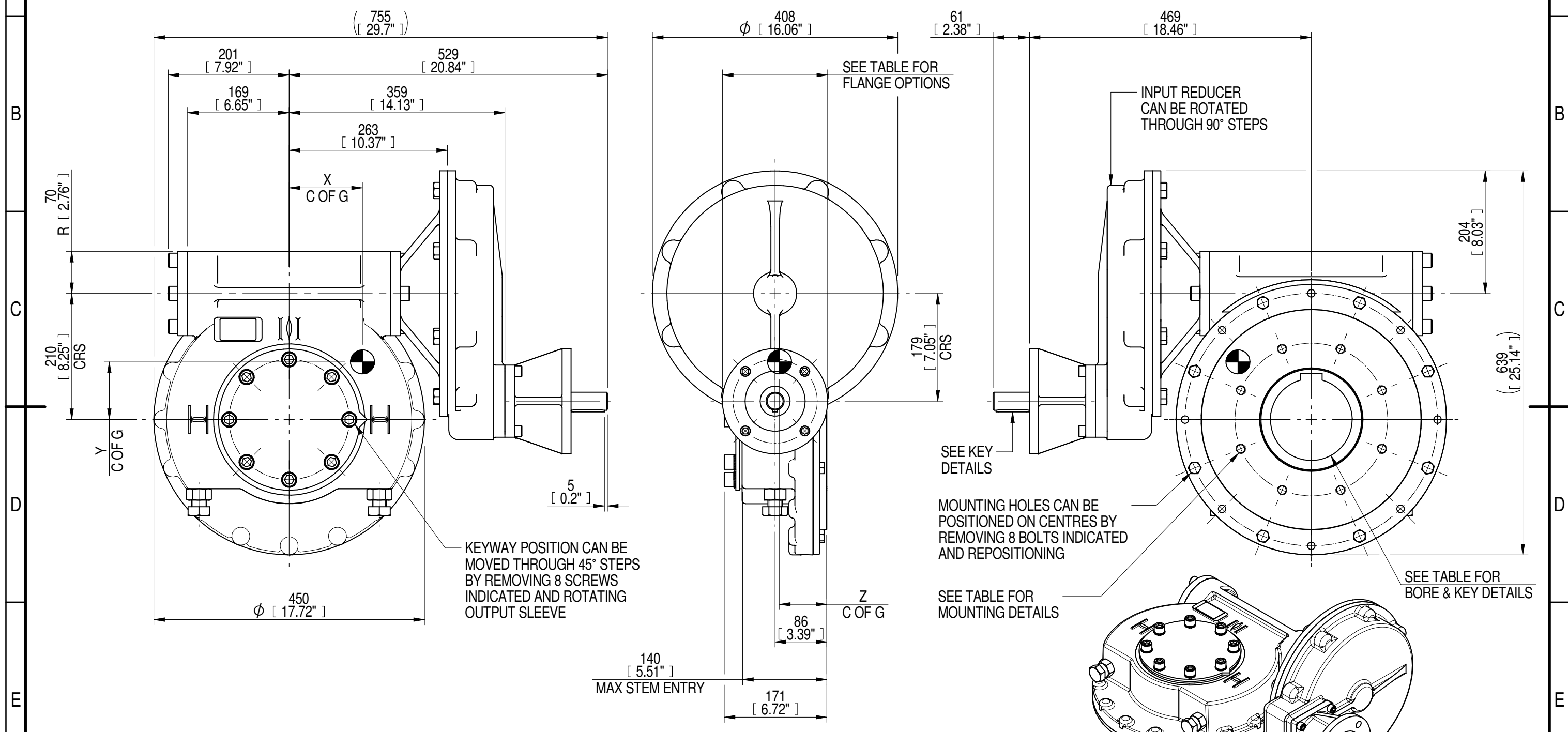

PLAN VIEW OF GEARBOX IN CLOSED POSITION SHOWING STANDARD KEYWAY POSITIONS. ALTERNATIVES AVAILABLE ON REQUEST

- NOTES:
- * THREAD DEPTH DOES NOT MATCH ISO STANDARD
 - CENTRE OF GRAVITY POSITION IS INDICATIVE FOR STANDARD BUILD WHEN IN POSITION SHOWN

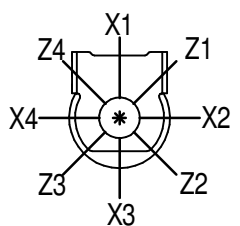

RATIO	TURNS TO CLOSE	M.A. ± 10%	WEIGHT (Kg)	MAX OUTPUT (Nm)	MAX INPUT (Nm)	X	Y	Z
720	180	285	163	15253	54	124	98	79
540	135	214	162	15253	71	123	96	79
480	120	189	161	15253	81	122	96	79
DESCRIPTION			TORQUE		CENTRE OF GRAVITY			

AS PART OF CONTINUOUS PRODUCT DEVELOPMENT, ALL DETAILS SUBJECT TO CHANGE WITHOUT PRIOR NOTICE. FOR UP TO DATE DETAILS PLEASE VISIT www.rotork.com

	This drawing is confidential and is the property of Rotork Gears and must not be reproduced either wholly or partly. All rights in respect of patents, designs and copyrights are reserved. ©2016	Document Type PUBLICITY	Title IW/MOW7 QUARTER TURN GEARBOX, 480/540/720 : 1, F14/ FA14 INPUT : F25/FA25 OUTPUT
	LEEDS - UK www.rotork.com	Dimensions in mm	Drawing Number PUB-IW7FBIRL-F14-F25