

INPUT FLANGE DETAILS							MOUNTING HOLES - BOLT CIRCLE (OFF CENTRES)								
INPUT FLANGE	FLANGE O/DIA. + THICKNESS	SHAFT DIA.	RECESS DIA.	RECESS DEPTH	HOLE DETAILS (45° OFF CENTRES)	KEY DETAILS	ISO 5211 / MSS SP-101 MOUNTING OPTION	HOLE DETAILS (22.5° OFF CENTRES)	STANDARD	MIN BORE	SQ KEY MAX BORE	SQ KEY SIZE	RECT. KEY MAX BORE	RECT. KEY SIZE	SQ BORE MAX
ISO F25	Ø300 x 20 (Ø11.81" x 0.787")	Ø30.00-0.03 (Ø1.181"-0.001")	Ø200.10+0.10 (Ø7.878"+0.004")	5 (0.20")	8 x Ø16.5 ON Ø254.0 P.C. (8 x Ø0.65" ON Ø10.00" P.C.)	8x7x55 (0.31"x0.28"x2.17")	ISO F30*	8 x M20 x 24 (0.94") DEEP ON Ø298.00 (Ø11.73") P.C.	BS4235	-	-	-	136	36 x 20	□ 108.8 (4.28")
FA25							FA30*		8 x 3/4" UNC x 24 (0.94") DEEP ON Ø298.45 (Ø11.75") P.C.	ANSI B17.1	-	4.875"	1.1/4" SQ.	5.25"	
							DIN 6885	-	-	-	-	136	36 x 20		

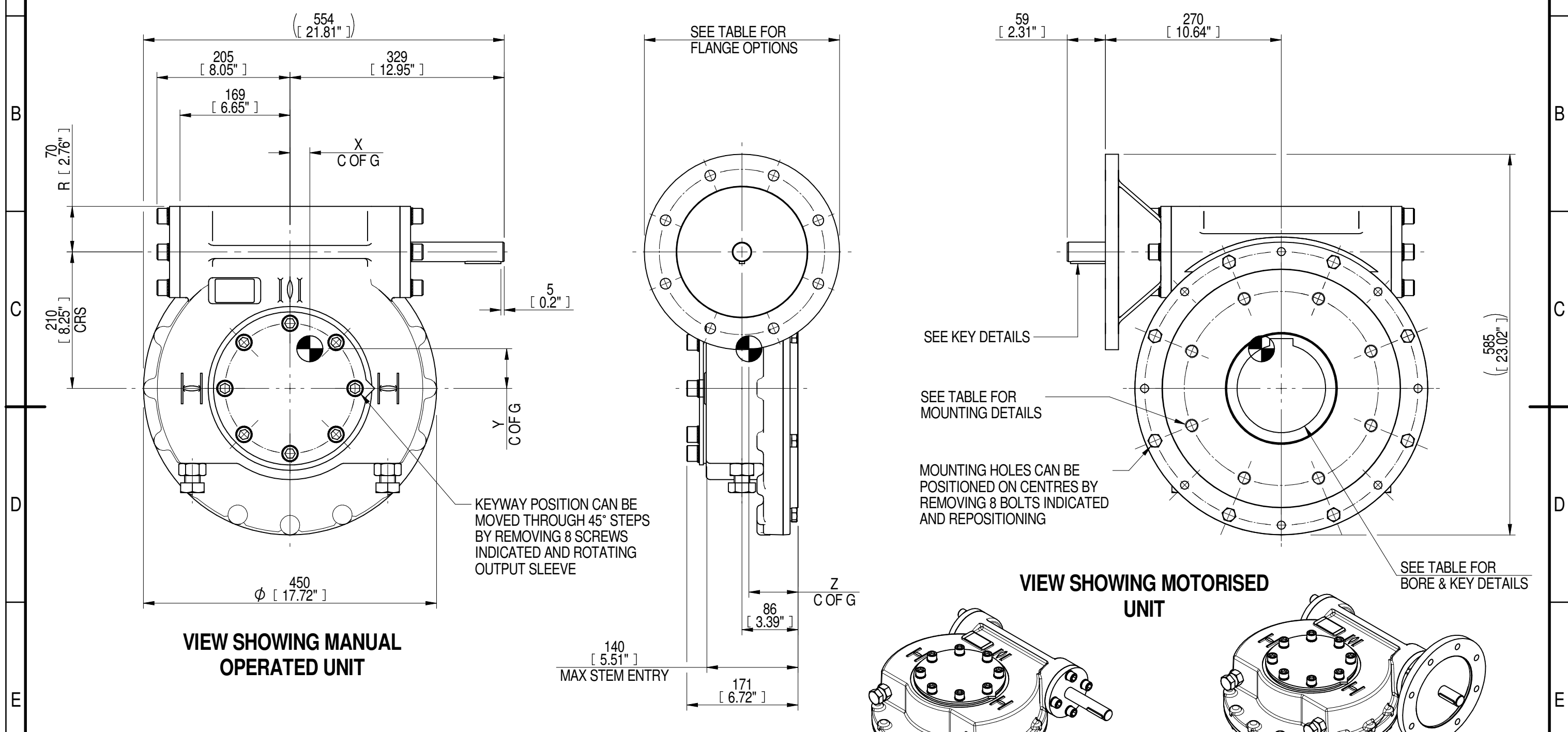

PLAN VIEW OF GEARBOX IN CLOSED POSITION SHOWING STANDARD KEYWAY POSITIONS. ALTERNATIVES AVAILABLE ON REQUEST

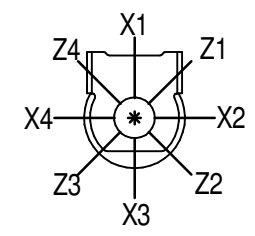

NOTES:
 1. * THREAD DEPTH DOES NOT MATCH ISO STANDARD
 2. CENTRE OF GRAVITY POSITION IS INDICATIVE FOR STANDARD BUILD WHEN IN POSITION SHOWN

DESCRIPTION	TORQUE	CENTRE OF GRAVITY
RATIO	MAX OUTPUT (Nm)	X
60	20000	30
15	800	61
25	30	75
109		
WEIGHT (Kg)	MAX INPUT (Nm)	Y
15	800	
M.A. ± 10%		Z

AS PART OF CONTINUOUS PRODUCT DEVELOPMENT, ALL DETAILS SUBJECT TO CHANGE WITHOUT PRIOR NOTICE. FOR UP TO DATE DETAILS PLEASE VISIT www.rotork.com

rotork Gears
 LEEDS - UK
www.rotork.com

This drawing is confidential and is the property of Rotork Gears and must not be reproduced either wholly or partly. All rights in respect of patents, designs and copyrights are reserved. ©2016

Document Type **PUBLICITY**
 Dimensions in mm

Title
**IW/MOW72 QUARTER TURN GEARBOX, 60:1
 MANUAL F25/ FA25 INPUT : F30/FA30
 OUTPUT**

Drawing Number
PUB-IW72FB-F25-F30

Sheet 1 of 1 Size A3