

TOP COVER ASSY

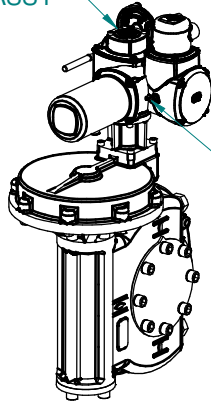

EARTHING POINT  
M6x1p x 10 DEEP

LARGE MOTOR

HAND LEVER

OIL DRAIN PLUG

OIL FILLER PLUG

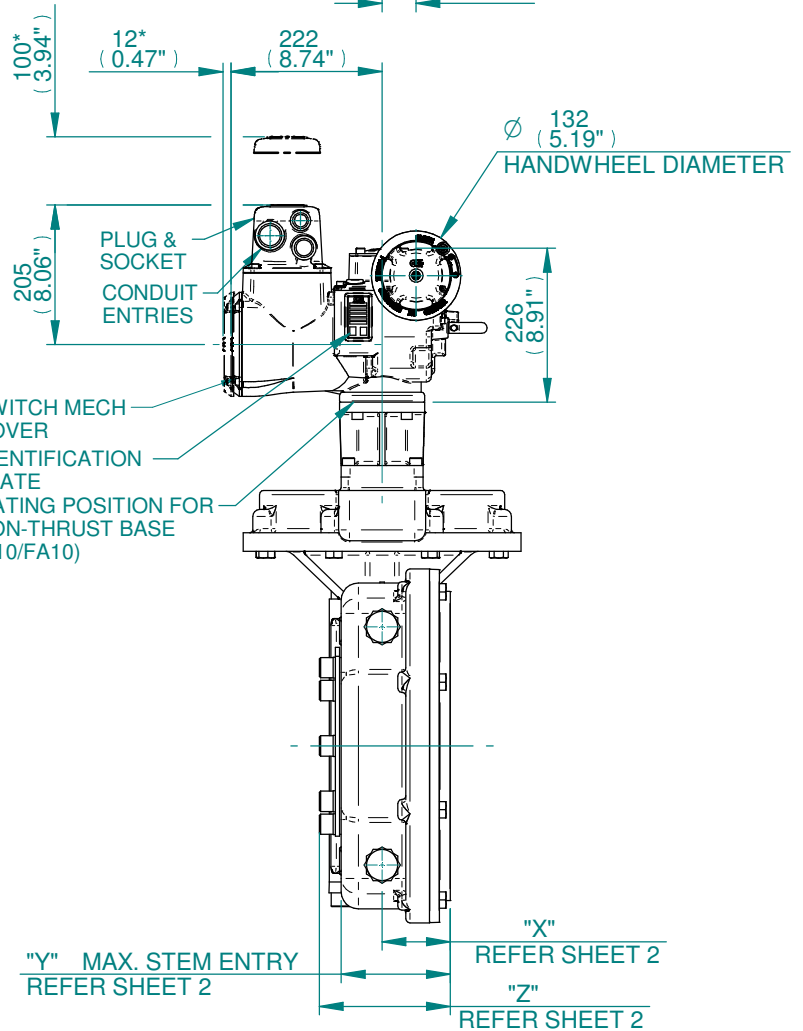
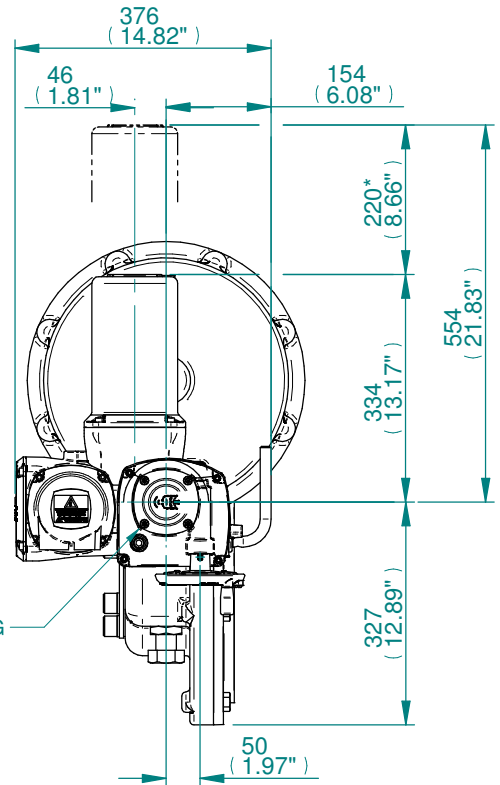

"Y" MAX. STEM ENTRY  
REFER SHEET 2

"X"  
REFER SHEET 2  
"Z"  
REFER SHEET 2

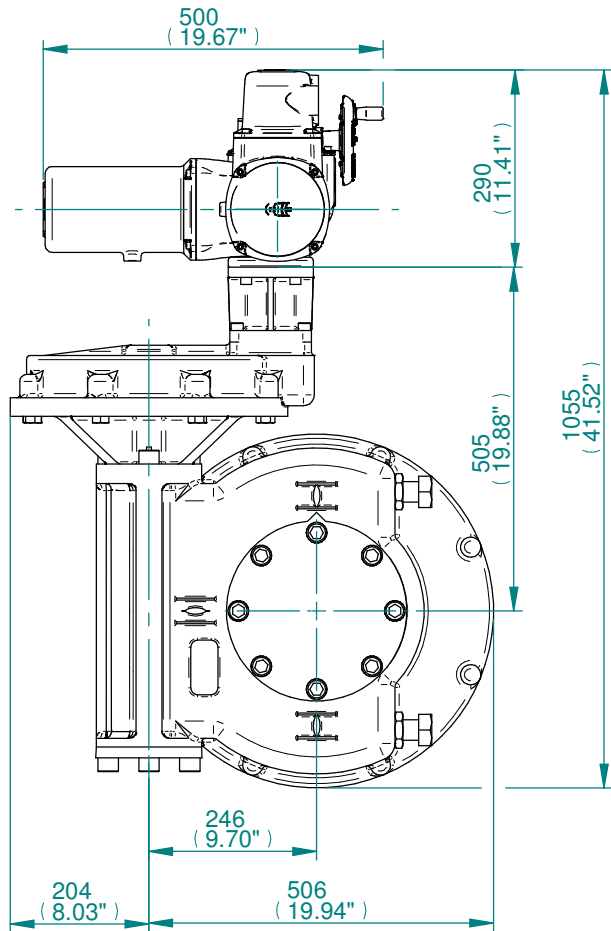

- NOTE:
1. GEARBOX RATIOS: 480,540,720:1.
  2. GEARBOX BASEPLATE: F25/FA25, F30/FA30, F35/FA35 & F40/FA40.
  3. DIMENSIONS WITH "\*" INDICATE COVER REMOVAL ALLOWANCE
  4. THE INTERFACE PROVIDED FOR MOUNTING THE ACTUATOR OR SECOND STAGE GEARBOX ONTO THE VALVE SHOULD CONFORM TO GOOD ENGINEERING PRACTICES, ENSURING ADEQUATELY TOLERANCED LIMITS FOR PARALLELISM, PERPENDICULARITY AND CONCENTRICITY.
  5. ROTORK CANNOT BE HELD LIABLE FOR DAMAGE TO OUR EQUIPMENT CAUSED BY EXCESSIVE LOADING FROM COVER TUBES, HANDWHEEL AND HAND LEVER.

PARAMETER	VALUE	DESCRIPTION
DRAWING TYPE	A	INSTALLATION DRAWING
ACTUATOR	2	CK(R)120
GEARBOX1	W8	IW8
GEARBOX2	BH	HIGH RATIO
TERMINAL COVER	B	3 COND
MECHANISM / MOTOR	0	STD.MECH./LARGE MOT.
HANDWHEEL / REAR / FRONT	0	STD.H.W./STD.REAR/STD.FRNT.
ORIENTATION	0	STD.ORIENT.

<b>CK</b> range	Drawn	AASHAY	17-07-19
	Checked	TAMIL	17-07-19
	Approved	JOSE	17-07-19

**Title** DIMENSIONAL DRAWING, CK120 & CKR120, IW8, HIGH RATIO, 3 CONDUIT ENTRIES, LARGE MOTOR, STANDARD ORIENTATION

This drawing and the information it contains are property of Rotork Controls Limited, and they will not be reproduced or disclosed, in whole or in part, without the prior written consent of Rotork.

<b>A4</b>	<b>Doc Number</b>	<b>Ver No</b>	<b>Scale</b>	<b>Sheet No</b>
	<b>A2W8RHB000X</b>	<b>1</b>	<b>NTS</b>	<b>1 of 2</b>

CONDUIT ENTRY HOLE		
Hole	Metric	NPT
A	M32	1 ¼"
B	M25	¾"
C	M20	¾"

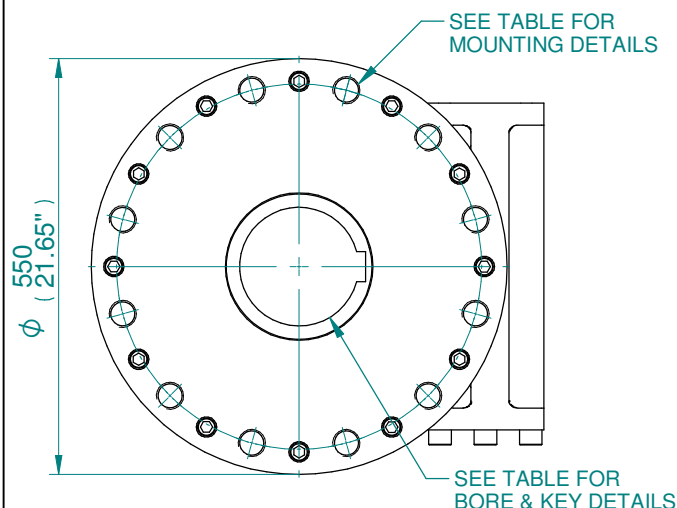
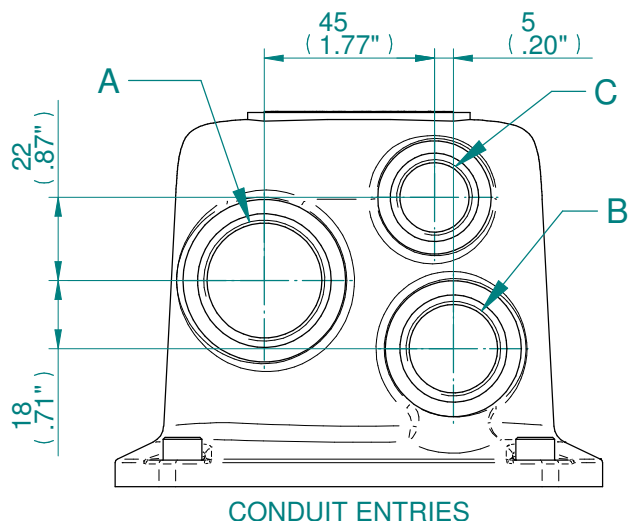

IW8 GEARBOX MOUNTING DETAILS FOR F48/FA48

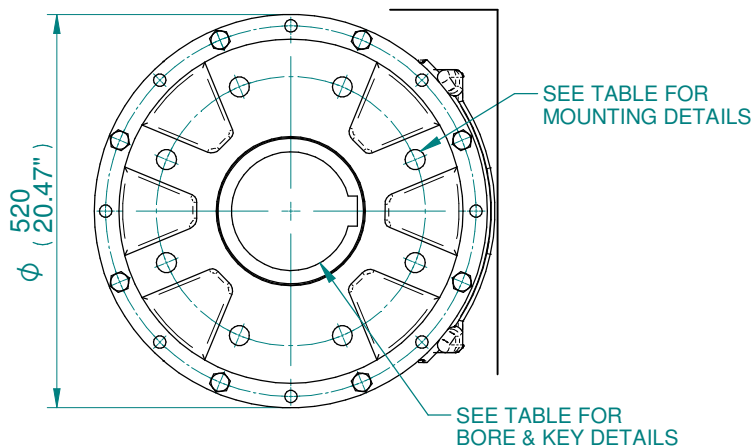

IW8 GEARBOX MOUNTING DETAILS FOR F25/FA25, F30/FA30, F35/FA35 & F40/FA40

BASEPLATE	X	Y	Z
STANDARD THICKNESS	99	160	193
FILLED THICKNESS	99	160	193
WAFER THICKNESS	137	198	231

STD	MAX BORE SQ KEY		MAX BORE RECTANGULAR KEY	
	BORE	KEY	BORE	KEY
BS4235	-	-	157	40 x 22
BS46	5.625"	1.1/2" SQ.	6.00"	1.1/2" x 1"
ANSI B17.1	5.625"	1.1/2" SQ.	6.00"	1.1/2" x 1"

BASEPLATE DETAILS			
TYPE	BASEPLATE	HOLE DETAILS (22.5° OFF CENTRES)	
ISO F25	STANDARD & FILLED	8 HOLES M16X30 (1.18") DEEP ON Ø254.0 (Ø10.00") P.C.	
FA25		8 HOLES 5/8"UNCX30 (1.18") DEEP ON Ø254.0 (Ø10.00") P.C.	
ISO F30		8 HOLES M20X30 (1.18") DEEP ON Ø298.0 (Ø11.73") P.C.	
FA30		8 HOLES 3/4"UNCX30 (1.18") DEEP ON Ø298.0 (Ø11.73") P.C.	
ISO F35		8 HOLES M30X30 (1.18") DEEP ON Ø356.0 (Ø14.02") P.C.	
FA35		8 HOLES 1"UNCX30 (1.18") DEEP ON Ø355.6 (Ø14.00") P.C.	
ISO F40		8 HOLES M36X36 (1.42") DEEP ON Ø406.0 (Ø15.98") P.C.	
FA40		8 HOLES 1.25"UNCX36 (1.42") DEEP ON Ø406.4 (Ø16.00") P.C.	
TYPE		BASEPLATE	HOLE DETAILS (15° OFF CENTRES)
ISO F48		WAFER	12 HOLES M36X36 (1.42") DEEP ON Ø483.00 (Ø19.02") P.C.
FA48			12 HOLES 1.25"UNCX36 (1.42") DEEP ON Ø482.6 (Ø19.00") P.C.

<b>CK</b> range	Drawn	AASHAY	17-07-19
	Checked	TAMIL	17-07-19
	Approved	JOSE	17-07-19

**Title** DIMENSIONAL DRAWING, CK120 & CKR120, IW8, HIGH RATIO, 3 CONDUIT ENTRIES, LARGE MOTOR, STANDARD ORIENTATION

This drawing and the information it contains are property of Rotork Controls Limited, and they will not be reproduced or disclosed, in whole or in part, without the prior written consent of Rotork.

<b>A4</b>	Doc Number	Ver No	Scale	Sheet No
	<b>A2W8RHB000X</b>	<b>1</b>	<b>NTS</b>	<b>2 of 2</b>