

- NOTE:
1. GEARBOX RATIOS: 180,240,360,480,540 & 720:1.
 2. GEARBOX BASEPLATE: F30/FA30,F35/FA35,F40/FA40 & F48/FA48.
 3. DIMENSIONS WITH "*" INDICATE COVER REMOVAL ALLOWANCE
 4. THE INTERFACE PROVIDED FOR MOUNTING THE ACTUATOR OR SECOND STAGE GEARBOX ONTO THE VALVE SHOULD CONFORM TO GOOD ENGINEERING PRACTICES, ENSURING ADEQUATELY TOLERANCED LIMITS FOR PARALLELISM, PERPENDICULARITY AND CONCENTRICITY.
 5. ROTORK CANNOT BE HELD LIABLE FOR DAMAGE TO OUR EQUIPMENT CAUSED BY EXCESSIVE LOADING FROM COVER TUBES, HANDWHEEL AND HAND LEVER.

PARAMETER	VALUE	DESCRIPTION
DRAWING TYPE	A	INSTALLATION DRAWING
ACTUATOR	3	CK(R)250/500
GEARBOX1	W9	IW9
GEARBOX2	RL	LOW RATIO
TERMINAL COVER	B	3 COND
MECHANISM / MOTOR	A	AID/LARGE MOT.
HANDWHEEL / REAR / FRONT	0	STD.H.W./STD.REAR/STD.FRNT.
ORIENTATION	0	STD.ORIENT.

CK range	Drawn	HAABI	15-10-19
	Checked	TAMIL	15-10-19
	Approved	JOSE	15-10-19

Title DIMENSIONAL DRAWING, CK250/500 & CKR250/500, IW9, LOW RATIO, 3 CONDUIT ENTRIES, AID/LARGE MOTOR, STANDARD ORIENTATION.

This drawing and the information it contains are property of Rotork Controls Limited, and they will not be reproduced or disclosed, in whole or in part, without the prior written consent of Rotork.

A4	Doc Number	Ver No	Scale	Sheet No
	A3W9RLBA00X	1	NTS	1 of 2

CONDUIT ENTRY HOLE		
Hole	Metric	NPT
A	M32	1 1/4"
B	M25	3/4"
C	M20	3/4"

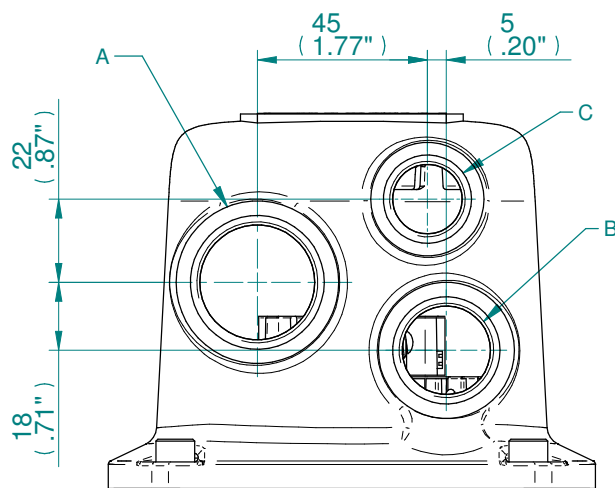

CONDUIT ENTRIES

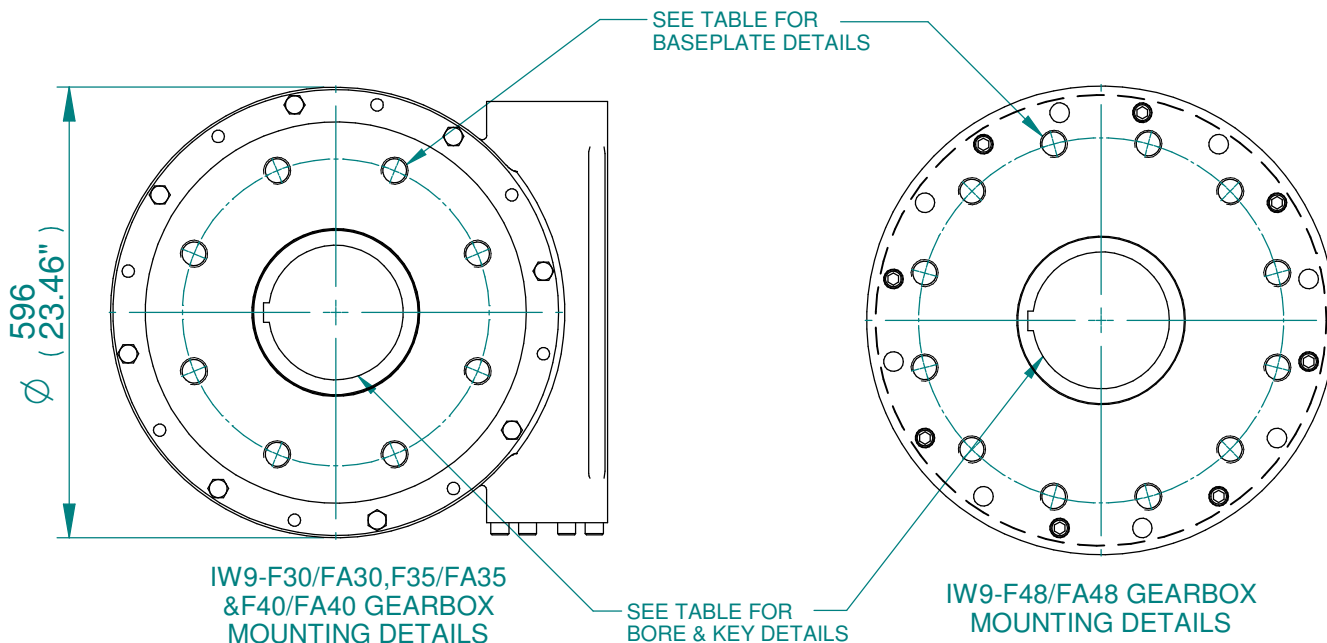

IW9-F30/FA30, F35/FA35 & F40/FA40 GEARBOX MOUNTING DETAILS

IW9-F48/FA48 GEARBOX MOUNTING DETAILS

BASEPLATE	X	Y	Z
STANDARD THICKNESS	100	168	201
FILLED THICKNESS	100	168	201
WAFER THICKNESS	127	195	228

STD	MAX BORE SQ KEY		MAX BORE RECTANGULAR KEY	
	BORE	KEY	BORE	KEY
BS4235	-	-	178	45X25
BS46	-	-	6.75"	1.75" x 1.25"
ANSI B17.1	6.50"	1.1/2" SQ.	6.50"	1.5" x 1"

BASEPLATE DETAILS			
TYPE	BASEPLATE	HOLE DETAILS (22.5° OFF CENTRES)	
ISO F30	STANDARD & FILLED	8 HOLES M20X25 (0.98") DEEP ON Ø298.0 (Ø11.73") P.C.	
FA30		8 HOLES 3/4"UNCX25 (0.98") DEEP ON Ø298.0 (Ø11.73") P.C.	
ISO F35		8 HOLES M30X36 (1.42") DEEP ON Ø356.0 (Ø14.02") P.C.	
FA35		8 HOLES 1"UNCX36 (1.42") DEEP ON Ø355.6 (Ø14.00") P.C.	
ISO F40		8 HOLES M36X36 (1.42") DEEP ON Ø406.0 (Ø15.98") P.C.	
FA40		8 HOLES 1.25"UNCX36 (1.42") DEEP ON Ø406.4 (Ø16.00") P.C.	
TYPE		BASEPLATE	HOLE DETAILS (15° OFF CENTRES)
ISO F48		WAFER	12 HOLES M36X36 (1.42") DEEP ON Ø483.00 (Ø19.02") P.C.
FA48	12 HOLES 1.25"UNCX36 (1.42") DEEP ON Ø482.6 (Ø19.00") P.C.		



Drawn	HAABI	15-10-19
Checked	TAMIL	15-10-19
Approved	JOSE	15-10-19

Title DIMENSIONAL DRAWING, CK250/500 & CKR250/500, IW9, LOW RATIO, 3 CONDUIT ENTRIES, AID/LARGE MOTOR, STANDARD ORIENTATION.

This drawing and the information it contains are property of Rotork Controls Limited, and they will not be reproduced or disclosed, in whole or in part, without the prior written consent of Rotork.

A4	Doc Number	Ver No	Scale	Sheet No
	A3W9RLBA00X	1	NTS	2 of 2