

rotork[®] Gears

Gearbox Instruction Manual

Rotork Gears gearbox ranges

IW, MOW, MTW, IB, IS, HOB/MPR & HOS/MPR



- ! This manual contains important safety information. Thoroughly read and understand it before installing the gearbox.**
- ! This manual enables a competent person to install, operate, adjust and inspect Rotork gearboxes. Only persons competent by their training or experience should install, maintain and repair Rotork gearboxes.**

An electronic copy of this manual is available on www.rotork.com

Contents

1	General Information	2
2	Health and Safety.....	3
3	Storage.....	3
4	Unpacking.....	3
5	Handling	3
6	Installation and Maintenance of Worm Gearboxes	4
6.1	Output Sleeve Removal, Machining and Re-Fitting	4
6.2	Mounting to the Valve	6
6.3	Baseplate Thread Depths	7
6.4	Mounting an actuator to the gearbox.....	8
6.5	Setting the Gearbox Stops to Suit the Valve (IW and MOW Only)	8
7	Installation of Bevel and Spur Gearboxes	9
7.1	Output Sleeve Removal, Machining and Re-Fitting	9
7.1.1	Output Sleeve Removal.....	9
7.1.2	Output Sleeve Handling	9
7.1.3	Re-fitting Output Sleeve.....	10
7.2	Mounting to the Valve	11
7.2.1	General mounting instructions (all gearboxes)	11
7.2.2	Mounting gearbox sizes 2 to 13, 15 and 17	12
7.2.3	Mounting gearbox sizes 14, 16 and 18 to 21.	13
7.2.4	Mounting a cover tube to the gearbox	13
7.2.5	Mounting an actuator to the gearbox	14
8	Gearbox Maintenance	14
8.1	Worm Gearbox Maintenance	14
8.2	Bevel and Spur Gearbox Maintenance Instructions	14
9	Gearbox Operation	15
10	Paint Repair Procedure	15
11	Tightening torques.....	15
12	Handwheel Mass by Type and Size.....	16

1 General Information

In this manual, the term 'worm gearboxes' refers to the following ranges of Rotork gearboxes: IW, MOW and MTW.

The term 'bevel and spur gearboxes' refers to the following ranges: IB, IS, HOB/MPR and HOS/MPR.

2 Health and Safety

Work undertaken must be carried out in accordance with the instructions in this and any other relevant manuals. The user and those persons working on this equipment should be familiar with their responsibilities under any statutory provisions relating to the Health and Safety of their workplace. Due consideration of additional hazards should be taken when using the gearbox with other equipment. Should further information and guidance relating to the safe use of the Rotork products be required, it will be provided on request.

The mechanical installation should be carried out as outlined in this manual and in accordance with relevant standards such as British Standard Codes of Practice. No inspection or repair should be undertaken unless it conforms to the specific hazardous area certification requirements. For maintenance of the actuator, refer to the actuator installation and maintenance manual.

! WARNING: The gearbox enclosure materials may include cast iron, SG iron, carbon steel or stainless steel.

3 Storage

Store the gearbox in a clean dry place until it is installed. Recommended storage temperature range: 0°C to 40°C (32°F to 104°F).

4 Unpacking

Do a risk assessment before unpacking and handling the gearbox. The risk assessment is the responsibility of the person doing this work.

Gearboxes are packed in a variety of configurations depending on size, type and quantity. Gearboxes are normally supplied fully assembled except for the handwheel.

The gearbox weight is recorded on the packaging and on a label attached to the gearbox.

Packaging materials used may include wood, cardboard, polyethylene and steel. Packaging should be recycled following local regulations.

5 Handling

! Individual weights for gearboxes are recorded on their respective nameplates

! Only trained and experienced personnel should carry out handling. At all times, safe handling must be ensured.

! Each combination must be assessed to identify all risks associated with handling.

! WARNING: The gearbox may present an unbalanced load. The gearbox must be fully supported until full valve shaft/stem engagement is achieved and the gearbox is secured to the valve flange.

! Once connected to the valve, each assembly must be assessed on an individual basis for safe handling/lifting.

! WARNING: Never lift the complete combination-valve assembly via the gearbox.

! If it is necessary to lift the gearbox using lifting equipment, certified soft slings are recommended.

! Damage to protective coatings should be correctly rectified and may invalidate warranty.

! We recommend fitting a bolt and washer system onto the baseplate of bevel and spur gearboxes before moving them, as illustrated in Figure 7 and Figure 10.

6 Installation of Worm Gearboxes

This section refers to the following gearbox ranges only: IW, MOW and MTW.

IW and MOW gearboxes are supplied with the stops set to a nominal 90° open and close position. The stops must be re-set for the stroke of the valve after installation (see below).

6.1 Output Sleeve Removal, Machining and Re-Fitting

All gearboxes except for IW12 to IW16 have a removable output sleeve (item 1, Figure 1). Unless specifically requested at the ordering stage, the output sleeve will be supplied blank and must be machined to suit the valve shaft.

IW12 to IW16 have an output which is directly machined as specified with the order.

Figure 1 shows the arrangement of the output sleeve in the gearbox. See Figure 2 for removing the output sleeve without damaging the sealing faces.

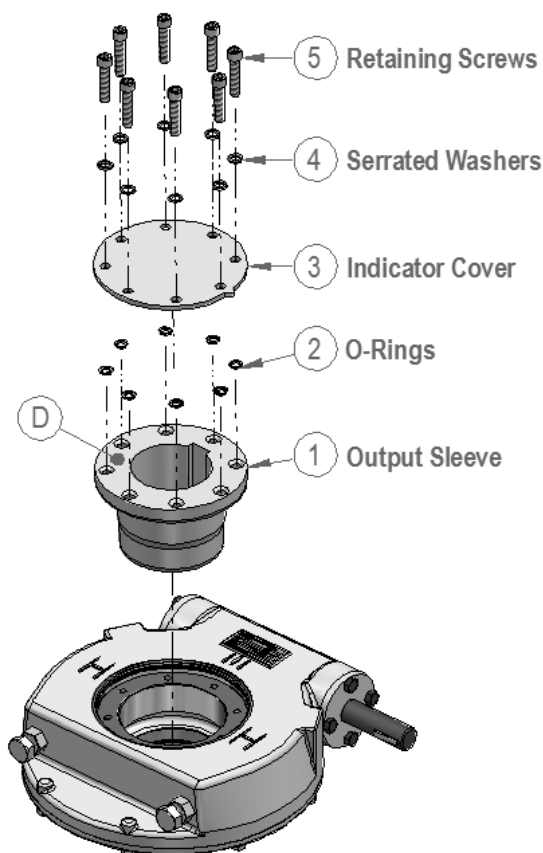

Figure 1 - Output Sleeve Arrangement

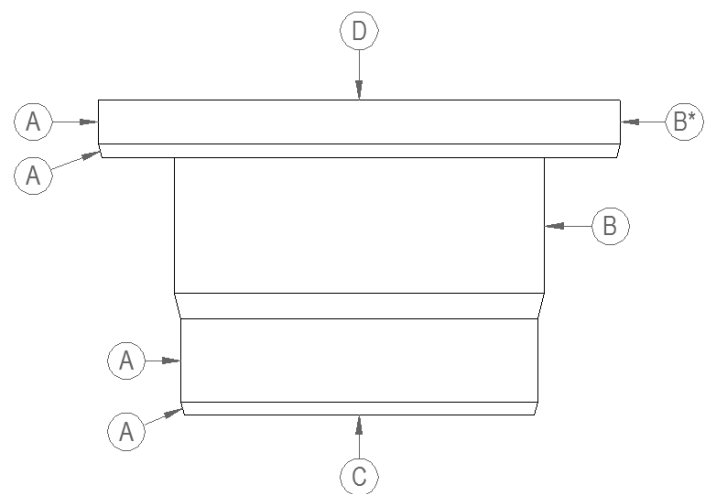

Figure 2 - Output Sleeve, Important Surfaces

Important Notes in Figure 2:

- A:** The surfaces marked 'A' are sealing or bearing faces and must not be damaged.
- B:** The surfaces marked 'B' can be used for chucking the output sleeve. *Note, this surface can only be used for chucking on MTW gearboxes, NOT IW or MOW units.
- C:** To remove the output sleeve from the gearbox, a force may have to be applied to the face marked 'C' of the output sleeve.
- D:** It is recommended to apply silicon sealant to the face marked 'D' when fitting the indicator plate.

Referring to the item numbers in Figure 1, the output sleeve can be easily removed from the top of the gearbox by first removing the retaining screws (5). The screws are either serrated under their heads or are fitted with serrated washers (4). Then remove the indicator/cover plate (3).

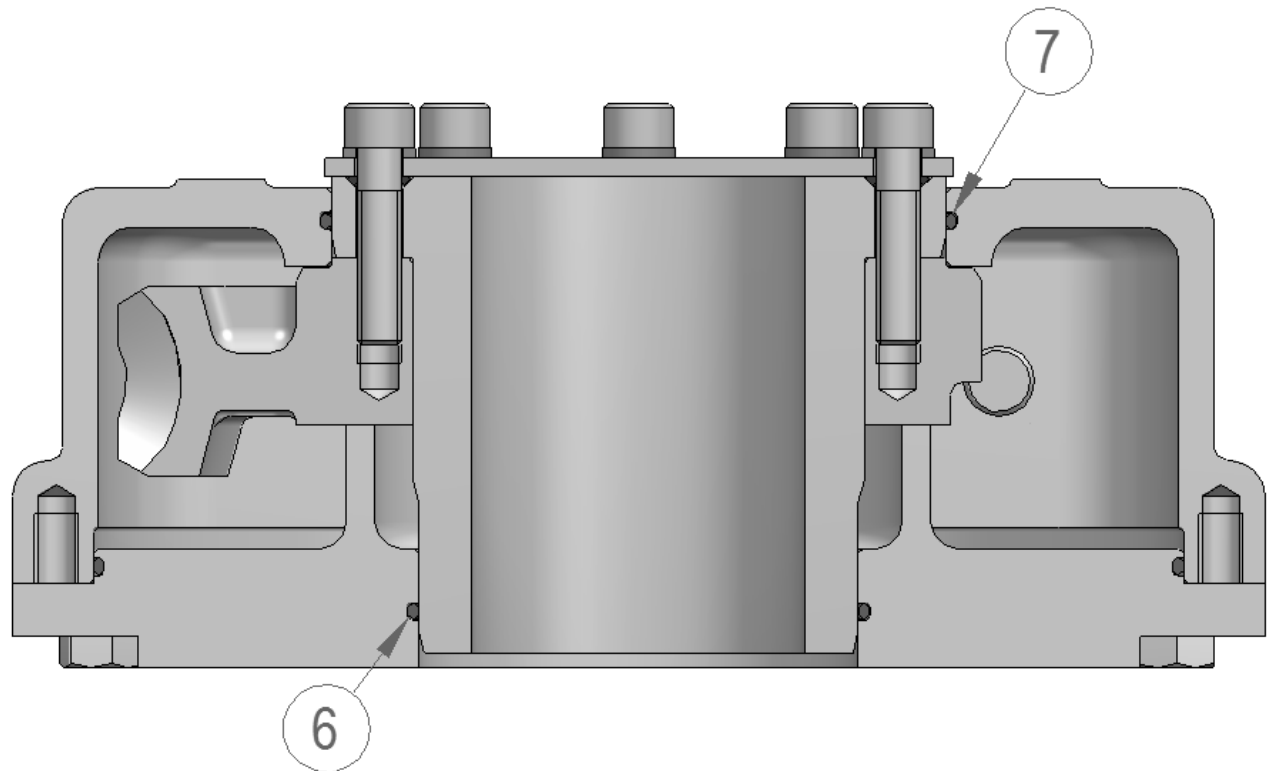

Figure 3 - O-Ring Inspection

Referring to Figure 3, O-rings (6) and (7) are to be inspected for damage, greased and properly seated before re-fitting the output sleeve. If the O-ring is damaged, then it should be replaced prior to fitting the output sleeve.

! WARNING: Removing the retaining screws will result in the loss of control of the valve.

Referring to Figure 1, O-rings (2) are used to seal the indicator plate, output sleeve and retaining screws. Upon final installation on the valve, screws (5) must be tightened to the correct torque figures as shown on the label on the underside of the indicator/cover plate.

Before re-fitting the output sleeve after machining, check that the surfaces marked 'A' in Figure 2 are not damaged. Damaged surfaces can break the gearbox seals and cause water ingress or grease leakage. Applying a thin layer of grease to the faces marked 'A' will make refitting of the sleeve easier.

As detailed in Figure 1 and Figure 2, it is recommended that silicon sealant is applied to face 'D' to seal the indicator/cover plate to the output sleeve. Taking care not to apply sealant to the O-rings (2) or the sealing faces with the O-rings.

Before re-assembly, clean and de-grease the top face of the output sleeve, underside of the indicator/cover plate, and the socket head cap screws. Make a note of the tightening torque required for the output sleeve screws on the label on the underside of the indicator plate. Insert the screws and washers into the holes in the indicator/cover plate, as per Figure 1.

It is essential to fit the two-part washers the correct way around with the cam faces of the washers joining. Place the O-rings over the screw threads and against the indicator plate. See Figure 4 for details.

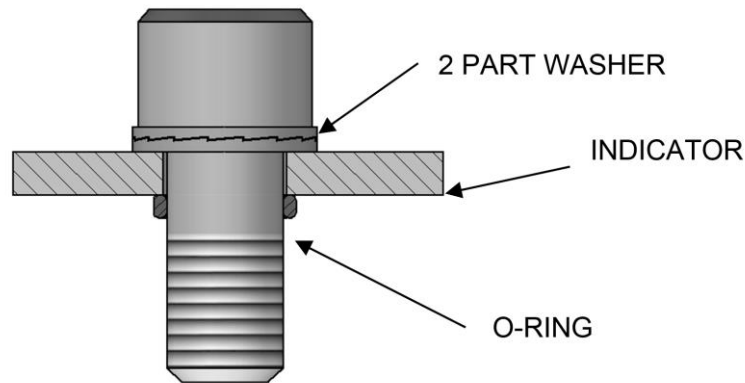

Figure 4 - Drive screw washer and O-ring arrangement

Apply a thin coat of silicon sealant to the top face of the output sleeve. Place the indicator on the output sleeve, with the indicator pointer in the correct orientation if applicable. Engage each screw through the indicator and output sleeve into the threaded holes in the gear quadrant. Fasten the screws evenly. As the screws start to tighten, press down on the indicator plate to extrude any excess sealant. Wipe away the excess. Tighten each screw to the recommended torque previously noted.

! IMPORTANT: It is essential to assemble and torque tighten the screws immediately after the sealant is applied to the indicator/cover plate and screws. Any delay will allow the sealant to start to cure. This will result in a flexible joint being formed between the output sleeve and indicator/cover plate. This joint would relax over time, allowing the screws to loosen.

6.2 Mounting to the Valve

! WARNING: Ensure the valve is fully supported and capable of accepting increased weight and change of centre of gravity resulting from the addition of the gearbox combination.

If the gearbox has been supplied with a handwheel, it is recommended that this be fitted to the gearbox before mounting onto the valve. This will make it easier to rotate the gearing to pick up on the valve stem, either key, flats or square.

- 1) Ensure gearbox output is in the same relative position as the valve shaft (open or closed). Gearbox output position can be moved by rotating the input shaft or turning the actuator handwheel.
- 2) It is recommended that flanges be sealed on assembly with silicon sealant. Apply a ring of silicone sealant around the mounting face of the flange, the ring should be at the same radius from the shaft as the bolt holes. Apply small rings of sealant around each of the bolt holes to completely seal the faces. The path marked 'D' in Figure 5 shows where sealant should be applied to the valve mounting flange.

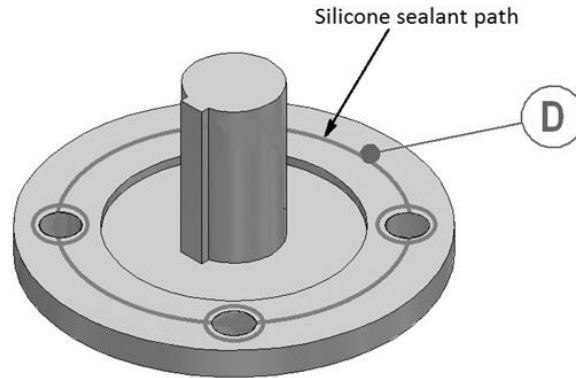

Figure 5 - Sealing of Valve Mounting Flange

- 3) Grease the output sleeve and the valve shaft.
- 4) Align gearbox baseplate flange square and parallel to valve flange.
- 5) Engage gearbox output sleeve onto the valve shaft ensuring the valve shaft keyway, square etc. is in alignment (if necessary rotate output sleeve – refer to step 1)
- 6) It is essential that the gearbox baseplate is flush with the valve bonnet flange before the mounting screws are tightened. Mounting screws or studs/nuts must be high tensile steel (grade 8.8 or higher). Firmly tighten down fixings onto the valve flange to the torque required. See Table 5.

6.3 Baseplate Thread Depths

Gearbox	Base	Min Thread Depth	Max Drill Depth
IW3 / MOW3	F/FA10, F/FA12	18	24
	F/FA14, F/FA16	24	27
IW4 / MOW4	F/FA12, F/FA14	16	20
	F/FA16	30	34
IW5 / IW52 / MOW5	F/FA14, F/FA16	20	25
	F/FA25	16	20
	F/FA25	30	34
IW6 / IW62 / IW63 / MOW6	F/FA16, F/FA25	16	25
	F/FA16, F/FA25, F/FA30	20	26
	F/FA30	30	34
IW7 / IW72 / MOW7	F/FA16, F/FA30	24	29
	F/FA30	24	28
	F/FA35	30	40
IW8 / IW82 / MOW8	F/FA25, F/FA30, F/FA35, F/FA40	24-36	30-40
	F/FA25, F/FA30, F/FA35	30	36
	F/FA40, F/FA48	36	46
IW9 / MOW9	F/FA30, F/FA35, F/FA40	25-36	34-44
	F/FA30, F/FA35, F/FA40	25-36	46
	F/FA40, F/FA48	36	44
IW10 / MOW10	F/FA35, F/FA40	30-36	41-46
	F/FA48	36	46
	F/FA60	36	46

IW11 / IW11BB / IW115 / IW115BB / MOW11	F/FA35, F/FA40, F/FA48	30-36	44
	F/FA60	36	39
IW12 / IW13	F/FA40, F/FA48, F/FA60	38	48
	F/FA48, F/FA60	38	48

Table 1 - Baseplate Mounting Hole Details

6.4 Mounting an actuator to the gearbox

If an actuator is to be used to operate the gearbox, then the mating faces between the gearbox input flange and the actuator output must be sealed prior to assembly using a ring of silicone sealant applied at the same radius as the bolt holes, a small ring of sealant should be applied around each bolt hole to completely seal the faces (see Figure 5). The actuator limit and torque switch settings should be set up following the actuator manufacturer's recommendations. The gearbox open & closed stop screws should then be set (see next section).

6.5 Setting the Gearbox Stops to Suit the Valve (IW and MOW Only)

The gearbox stops are factory set but require adjusting for optimum valve performance.

This procedure should be carried out by the valve maker/supplier and should be done when the valve opening and closing operations can be visibly checked. Once the valve is installed the stops should not be altered without the authorisation of the valve maker/supplier.

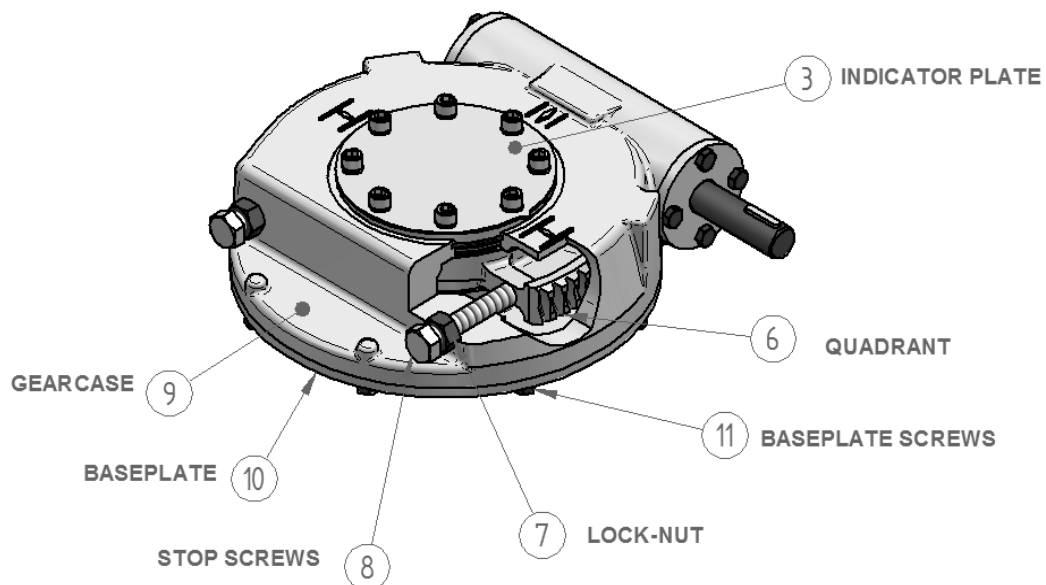

Figure 6 - Setting Stop-Bolts

Close the valve, using the actuator where applicable. Referring to Figure 6, use the indicator plate (3) pointer as an indication of position.

Loosen the lock nuts (7) and turn the stop screws out approximately 3 complete turns, apply a small amount of silicone sealant to the threads where the screws meet the gearcase. Operate the gearbox to the closed position and screw in stop screw (8) until it touches the gearbox quadrant (6). Rotate the screw back one turn, then tighten the lock-nut (7) to secure the stop screw. Open the valve with the actuator, and then repeat the process with the open position stop screw. If the stop screws are re-adjusted at a later date, then silicone sealant must be re-applied.

Note – movement between baseplate (10) and gearcase (9) can occur when operating at near rated torques. It is recommended that regular maintenance occurs to verify baseplate screws (11) are correctly torqued.

7 Installation of Bevel and Spur Gearboxes

This section refers to the following gearbox ranges only: IB, IS, HOB/MPR and HOS/MPR.

7.1 Output Sleeve Removal, Machining and Re-Fitting

All gearboxes have a removable output sleeve. Unless specifically requested at the ordering stage, the output sleeve will be supplied blank and must be machined to suit the valve stem.

7.1.1 Output Sleeve Removal

Refer to Figure 7. The output sleeve arrangement is identical for all gearboxes although large gearboxes have cylindrical roller thrust bearings instead of needle roller bearings.

The output sleeve (14) can be easily removed from the gearbox by first removing the spigot ring (15) from the baseplate (16). A small force may have to be applied to the face marked 'C' in Figure 8 to assist in removing the output sleeve.

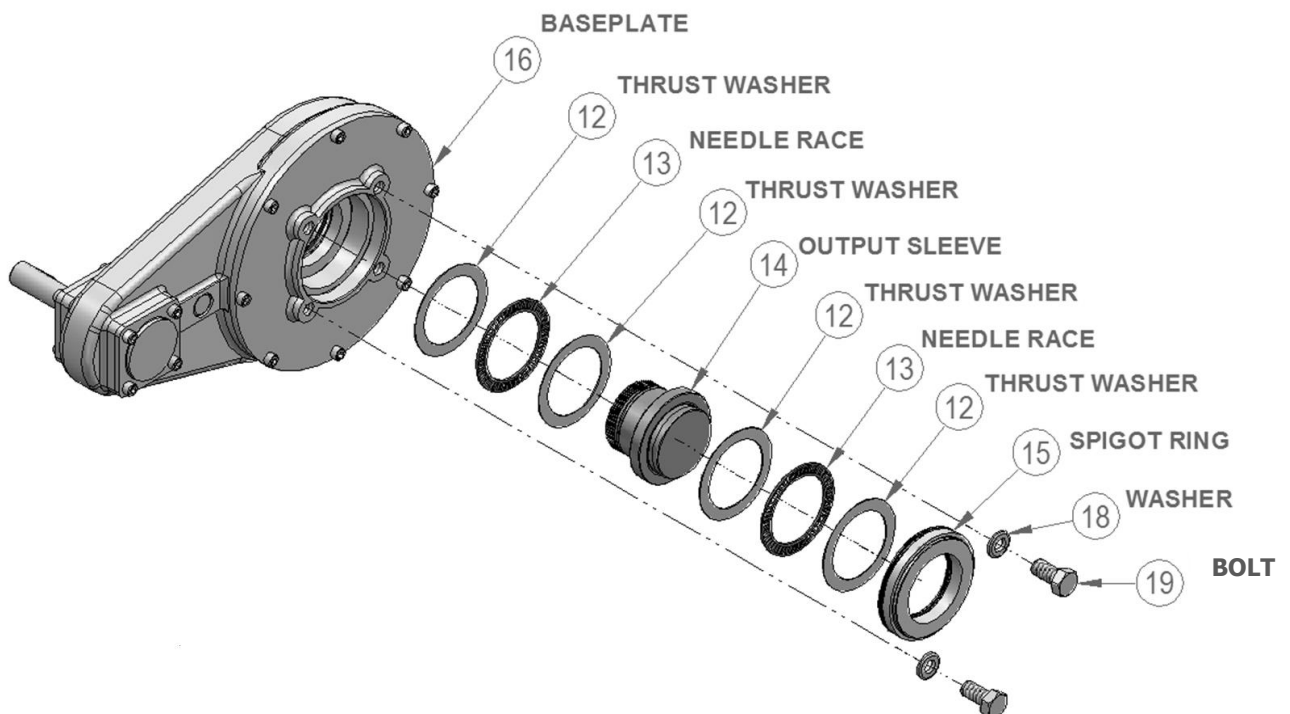

Figure 7 – Bevel and Spur Gearbox Output Sleeve Assembly

7.1.2 Output Sleeve Handling

For all gearboxes, apart from HOB3, see Figure 8. For the HOB3 gearbox, see Figure 9.

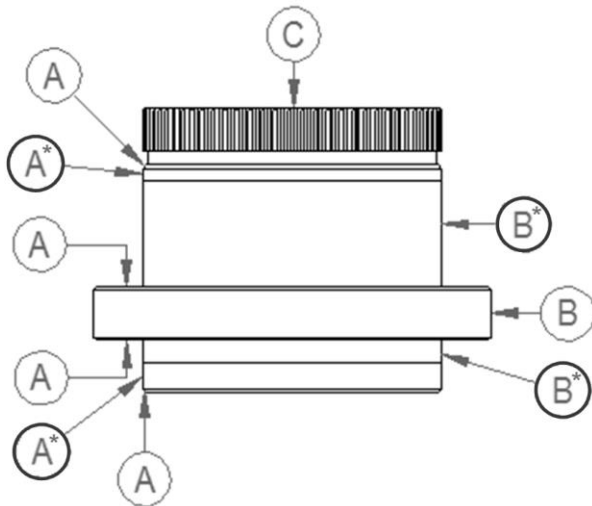

Figure 8 - Spined Output Sleeve, Important Surfaces

Important Notes:

- A: The surfaces marked 'A' are sealing or bearing faces and must not be damaged.
- B: The surface marked 'B' can be used for chucking the output sleeve for machining.
- C: To remove the output sleeve from the gearbox, a force may have to be applied to the face marked 'C' of the Output Sleeve.

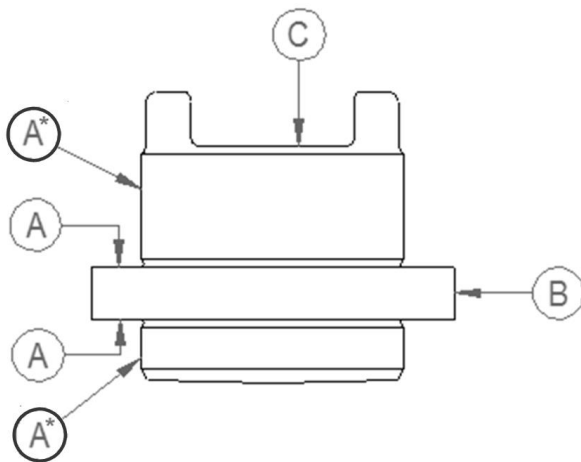

Figure 9 – HOB3 Dog Drive Output Sleeve, Important Surfaces

Important Notes:

- A: The surfaces marked 'A' are sealing or bearing faces and must not be damaged.
- B: The surface marked 'B' can be used for chucking the output sleeve for machining.
- C: To remove the output sleeve from the gearbox, a force may have to be applied to the face marked 'C' of the Output Sleeve.

7.1.3 Re-fitting Output Sleeve

- ! **IMPORTANT:** Before re-fitting the output sleeve after machining, check that the surfaces marked 'A' in Figure 8 and Figure 9 are not damaged. Damaged surfaces can break the gearbox seals or bearings and cause water ingress or grease leakage.
- ! **IMPORTANT:** The thrust bearings in the output **MUST** be fitted correctly, along with the output sleeve and the spigot ring. Refer to Figure 7. The thrust bearings (13) **MUST** have a thrust washer (12) at each side of the bearing. A bearing / washer assembly **MUST** be fitted at each side of the output sleeve thrust shoulder.
- ! **IMPORTANT:** The thrust bearings and output sleeve must be thoroughly greased with appropriate grease before fitting back into the gearbox/valve. Note the spigot ring has an internal and external seal that should also be greased.

An anti-friction compound containing molybdenum disulphide, such as MI-Setral-9M, should be applied to the faces marked with an asterisk '*' in Figure 8 and Figure 9 before inserting the output sleeve back into the gearbox. For clarification on the suitability of an anti-friction compound, please contact Rotork Gears.

All output sleeves except for the HOB3 are splined and may have to be rotated slightly to engage with the mating spline in the output gear. The HOB3 has a dog drive which needs to be aligned to the mating sections on the output gear.

- ! We recommend fitting a bolt (19) and washer (18) fixture into the base of the gearbox as illustrated in Figure 7 and Figure 10. Note that the washers must overlap the spigot ring (15). This will stop the output sleeve assembly from becoming detached from the main body. The bolts and washers are not supplied by Rotork Gears.

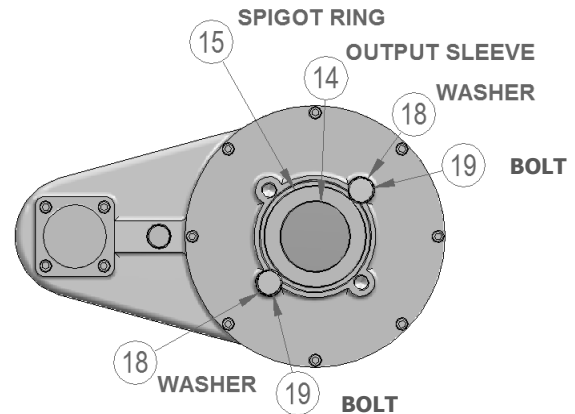

Figure 10 - Securing Spigot Example

7.2 Mounting to the Valve

7.2.1 General mounting instructions (all gearboxes)

- ! **WARNING:** Ensure the valve is fully supported and capable of accepting increased weight and change of centre of gravity resulting from the addition of the actuator-gearbox combination. The recommended maximum unsupported length for cover tubes is shown in table 2.
- ! **IMPORTANT:** Before fitting the output sleeve, check that the surfaces marked 'A' in Figure 8 and Figure 9 are not damaged. Damaged surfaces can break the gearbox seals or bearings and cause water ingress or grease leakage.
- ! **IMPORTANT:** Bearings, Output sleeve and Valve Stem/shaft should be thoroughly greased with appropriate grease before fitting into the gearbox/valve. Note the spigot ring has an internal and external seal that should also be greased.
- ! **IMPORTANT:** Threaded valve stems must be thoroughly lubricated with grease before fitting the output sleeve.

An anti-friction compound containing molybdenum disulphide, such as MI-Setral-9M, should be applied to the faces marked with an asterisk '*' in Figure 8 and Figure 9 before inserting the output sleeve back into the gearbox. For clarification on the suitability of an anti-friction compound, please contact Rotork Gears.

Ensure that the gearbox baseplate is parallel to the valve flange when lowering. This will avoid jamming.

It is recommended that a silicon sealant is used between the gearbox baseplate and the valve flange. 'D' in Figure 11 highlights where this sealant should be applied.

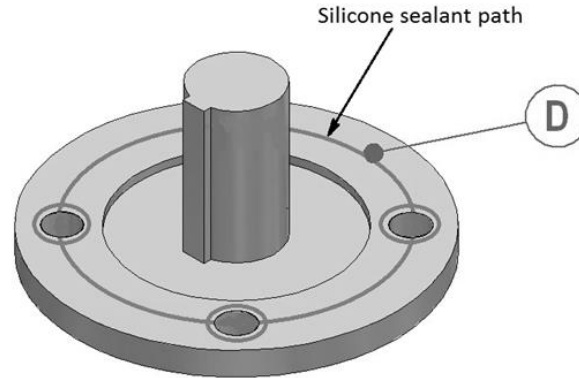

Figure 11 - Sealing of Valve Mounting Flange

If the gearbox has been supplied with a handwheel, it is recommended that this be fitted to the gearbox before mounting onto the valve. This will make it easier to rotate the gearing to pick up the valve stem, key, thread or spline location.

When lowering the gearbox onto the valve rotate the handwheel to ensure the gearbox internal splines correctly engage with the external splines on the output sleeve. Once engaged keep lowering the gearbox until the valve and gearbox flanges are in contact. Align mounting base holes and secure using screws or studs with a minimum tensile strength of 800 N/mm². Tighten fasteners onto the valve flange to the torque required. See Table 5.

7.2.2 Mounting gearbox sizes 2 to 13, 15 and 17

In addition to the points in Section 7.2.1, it is recommended that the machined output sleeve assembly is assembled onto the valve stem first and then the gearbox lowered onto the output sleeve assembly. See Figure 12 and Figure 13 for assembly details.

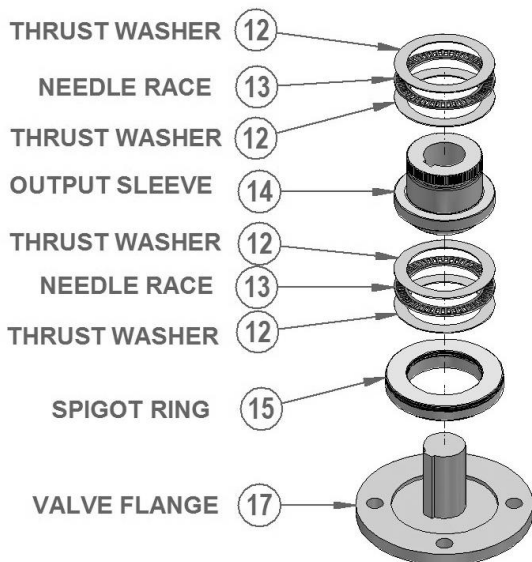

Figure 12 - Valve Stem Assembly

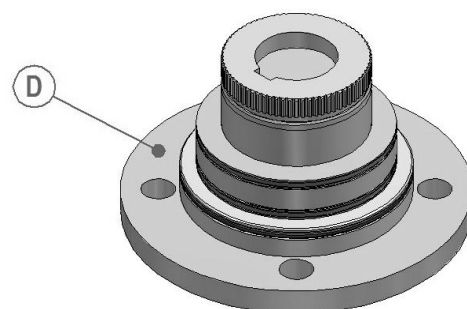

Figure 13 - Valve Stem (Assembled)

Fit the machined output sleeve (14), thrust bearings (12 & 13) and baseplate spigot ring (15) on the valve shaft as shown in the Figure 12. Bearings should be lubricated with the appropriate grease (see Table 4). Grease the bearings, output sleeve and valve stem. Note that the spigot ring has an internal and external seal that should also be greased.

7.2.3 Mounting gearbox sizes 14, 16 and 18 to 21.

In addition to the points in Section 7.2.1, it is recommended that the cylindrical roller bearings and machined output sleeve are assembled onto the valve stem first and then the gearbox lowered to locate on the output sleeve assembly. See Figure 14 for assembly details:

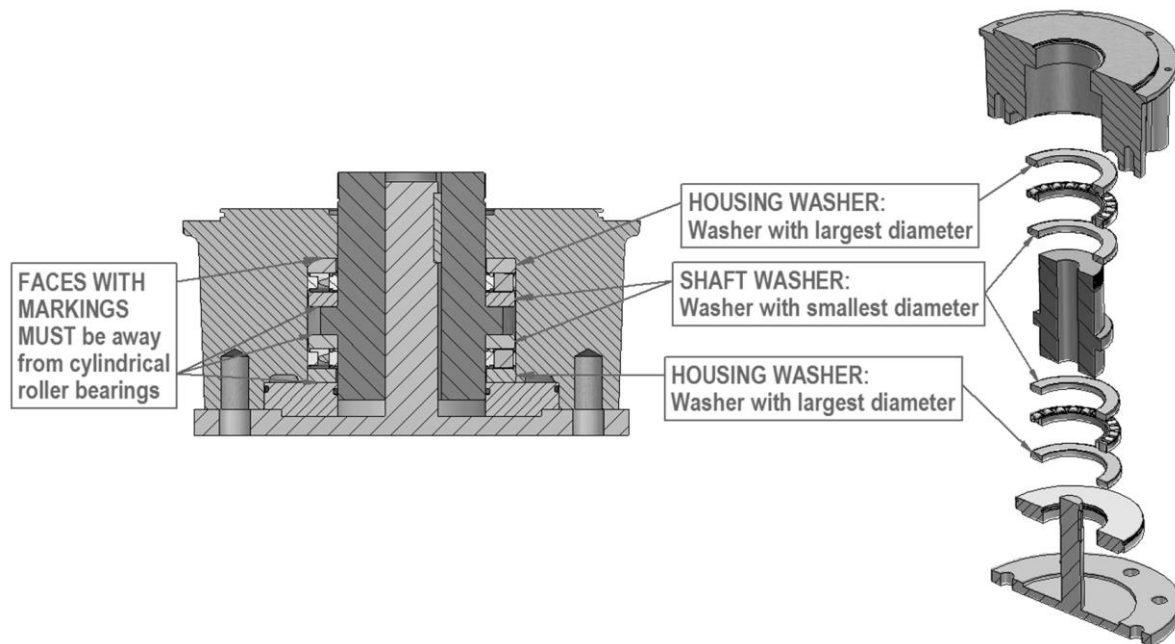

Figure 14 - Valve Stem Assembly with Cylindrical Roller Bearings

Fit in the following order:

1. Spigot Ring
2. Housing Washer (Largest Outside Diameter)
3. Bearing
4. Shaft Washer (Smallest Outside Diameter)
5. Output Sleeve
6. Shaft Washer (Smallest Outside Diameter)
7. Bearing
8. Housing washer (Largest Outside Diameter)

The washer faces that are either chamfered or have markings **MUST FACE AWAY** from the bearings to decrease wear on the bearing. Bearings should be lubricated with the appropriate grease. Grease the output sleeve and valve stem. Note that the spigot ring has an internal and external seal that should also be greased.

7.2.4 Mounting a cover tube to the gearbox

For rising stem valves, a cover tube may be fitted to protect the valve stem. Screw or bolt the cover tube into the gearbox and seal with a suitable sealant to prevent water ingress.

! WARNING: Do not pack the cover tube with grease as this can lead to a pressure build up in the cover tube.

Cover tubes are extensions to the gearcase and damage to the cover tube can cause damage to the gearcase. It is essential that the cover tubes are protected or supported to avoid side loads because of the environment or the application. See Table 2:

Gearbox Size	Maximum Unsupported Tube Length
3 to 5	2.0m (6.6ft)
6 to 7	2.8m (9.2ft)
8 to 9	3.0m (9.8ft)
10 to 21	5.0m (16.4ft)

Table 2 - Maximum Unsupported Tube Lengths

7.2.5 Mounting an actuator to the gearbox

If an actuator is to be used to operate the gearbox, then the mating faces between the gearbox input flange and the actuator output must be sealed prior to assembly using a ring of silicone sealant applied at the same radius as the bolt holes, a small ring of sealant should be applied around each bolt hole to completely seal the faces (see Figure 5). The actuator limit and torque switch settings should be set up following the actuator manufacturer's recommendations.

8 Gearbox Maintenance

8.1 Worm Gearbox Maintenance

Under normal operating conditions, no maintenance is required for the gearbox. Should the valve be taken out of service for overhaul, the gearbox baseplate may be removed and the lubricant changed using one of the lubricants in Table 3. The baseplate must be sealed using silicone sealant on re-assembly, unless fitted with O-rings. These should be replaced.

Gearbox	Manufacturer	Name	Temperature Range
IW	Fuchs	Renolit CL-X2	-60°C to +120°C
MOW	Fuchs	Renolit LST 0	-20°C to +120°C
MTW	Fuchs	Renolit EPLITH 00	-10°C to +120°C

Table 3 - Recommended Lubrication for Worm Gearboxes

An equivalent extreme pressure lubricant may be used. For extreme temperature applications, please consult Rotork Gears.

8.2 Bevel and Spur Gearbox Maintenance

For standard duties, all gear cavities are lubricated for life with Fuchs Renolit CL-X2 grease. Under normal operating conditions, no maintenance is required for the gearbox. However, should the valve be taken out of service for overhaul, the gearbox baseplate may be removed and the grease changed using the following recommended lubricant. The baseplate must be sealed using silicone sealant on re-assembly, unless fitted with an O-ring. All O-rings should be renewed.

An anti-friction compound containing molybdenum disulphide, such as MI-Setral-9M should be applied to the faces marked with an asterisk '*' in figure 9, before inserting the output sleeve back into the gearbox. For clarification on the suitability of an anti-friction compound, please contact Rotork Gears.

Note: All thrust elements and bearing cavities must be re-greased and re-fitted in the correct order. The recommended lubricant is shown in Table 4.

Gearbox	Manufacturer	Name	Temperature Range
IB, IS, HOB/MPR & HOS/MPR	Fuchs	Renolit CL-X2	-60°C to +120°C

Table 4 - Recommended Lubrication for Bevel and Spur Gearboxes

An equivalent extreme pressure lubricant may be used. For extreme temperature applications, please consult Rotork Gears.

9 Gearbox Operation

! IMPORTANT: Under no circumstances should any additional lever device such as a wheel-key or wrench be applied to a gearbox handwheel to develop more force when closing or opening the valve. This may cause damage to the valve and/or gearbox or may cause the valve to become stuck in the seated/back-seated position.

10 Paint Repair Procedure

! IMPORTANT: Damage to protective coatings should be correctly rectified as soon as possible.

! Damage to coatings may invalidate warranty.

If paint repair is required, the following procedure should be followed:

- Clean surface using solvent if necessary.
- Rinse surface with clean fresh water to remove any foreign matter and traces of solvent.
- Abrade area using wet and dry sandpaper, or power sander, feather edges of sound intact paint around damaged area by 2.5 cm
- Apply paint system as per originally applied to unit ensuring that dry film thickness (DFT) limits are met and time is allowed for each coat to cure. All as per the paint manufacturer's data sheets.

Ambient Conditions - No cleaning or coating application shall be undertaken if:

- The relative humidity is more than 85%
- The metal temperature is less than 3°C above the dew point.
- The ambient conditions are outside those stated in the paint manufacturer's data sheet for each coating.
- Coatings shall only be applied or cured at ambient and steel temperatures above 10°C or otherwise recommended by paint supplier.

11 Tightening torques

Table 5 shows recommended tightening torques for mounting the gearbox to the valve. Gearbox to valve fixing must conform to Material Specification ISO Class 8.8, yield strength 628 N/mm² to use Table 5 below:

Imperial Thread	Torque		Metric Thread	Torque	
	Nm	ft-lbf		Nm	ft-lbf
3/8"	34	25	M5	5	4
7/16"	55	40	M6	9	6
1/2"	83	61	M8	21	15

9/16"	120	89		M10	41	30
5/8"	166	122		M12	71	53
3/4"	291	215		M16	177	131
7/8"	469	346		M20	346	255
1"	702	518		M24	598	441
1 1/4"	1403	1035		M30	1189	877
1 1/2"	2441	1800		M36	2079	1533

Table 5 - Torque Tightening Figures

12 Handwheel Mass by Type and Size

Handwheel Type - mass kg (lb)					
Size in mm	CD (Cast)	PS (Pressed Steel)	SG (Steel - Welded)	S (Stainless Steel)	F/FS (Steel - Welded)
50	0.11 (0.24)	-	-	-	-
75	0.21 (0.46)	-	-	-	-
100	0.32 (0.71)	0.15 (0.33)	-	-	-
125	0.54 (1.19)	0.2 (0.44)	-	-	-
150	-	-	1 (2.20)	0.4 (0.88)	-
160	-	0.35 (0.77)	-	-	-
200	1 (2.20)	0.75 (1.65)	1.35 (2.98)	1 (2.20)	1 (2.20)
250	-	1.5 (3.31)	1.4 (3.09)	-	-
300	-	-	1.8 (3.97)	-	1.5 (3.31)
315	-	2 (4.41)	-	-	-
350	-	-	2.3 (5.07)	1.5 (3.31)	-
400	-	3.5 (7.72)	2.8 (6.17)	-	2.2 (4.85)
450	-	-	3 (6.61)	-	-
500	-	-	3.5 (7.72)	-	3 (6.61)
600	-	-	4.5 (9.92)	-	3.2 (7.05)
700	-	-	5 (11.02)	-	5.5 (12.13)
800	-	-	5.5 (12.13)	-	6.6 (14.55)
900	-	-	6 (13.23)	-	7.2 (15.87)
1000	-	-	-	-	8.4 (18.52)
1100	-	-	-	-	9.4 (20.72)
1200	-	-	-	-	10.27 (22.64)

Table 6 - Handwheel Mass by Type and Size