



Keeping the World Flowing
for Future Generations



There are two models of VRP precision relief valve in this range of products:

- VRP-032: Relatively high pressure and lower flow
- VRP-048: Lower pressure and higher flow

They are available in a choice of three different materials:

- Nitrile (Standard)
- Viton
- Nitrile (Low Temperature)

The VRP precision relief valve range has been designed to provide accurate overpressure protection in systems operating at pressures of up to 1380 bar (20015 psi) and flows of up to 25 l/min (5.5 gallons/min) for VRP-032, and up to 700 bar (10153 psi) and flows of up to 25 l/min (9.9 gallons/min) for VRP-048.

Precision relief valves have very high sealing forces along with accurate and narrow deadbands. Precision relief valves should be used in preference to spring relief valves where there is risk of vibration-induced leakage or where deadbands are important to system safety performance. Spring relief valves, typically, will have a narrow deadband when tested on a static dead weight tester but will have a much wider deadband under flowing conditions that will require a significant drop in system pressure to enable the valve to reseal.

The floating poppet design, enhanced by using linear bearings, produces a valve with a low pressure increase across the full range.

Installation and removal of system pipework is simplified by the right-angled porting configuration.

VRP Range

Pressure Relief Valve



Application

Pressure relief valves are used to provide an alternative flow path for liquids when there is an overpressure, potentially leading to leakage, equipment damage or health hazard.

Features

- Set point repeatability $\pm 3\%$
- Sealing re-seat pressure – virtually zero leakage
re-seat pressure $\geq 90\%$ of cracking pressure
- Important – set point is affected by vent port back pressure and will DECREASE accordingly
- The main spring load is not transmitted to the seat, thus reducing distortion and wear

Bifold[®]
A rotork[®] Brand

Environmental Specification

The environmental specification is the same for VRP-032 and VRP-048 valves but different for each material.

Material	Minimum Temperature	Maximum Temperature
Nitrile (Standard)	-20 °C	80 °C
Viton	-10 °C	80 °C
Nitrile (Low Temperature)	-40 °C	80 °C
Kalrez	-20 °C	80 °C
Silicone (VRP-048 only**)	-20 °C	80 °C
EPDM (VRP-048 only**)	-20 °C	80 °C

Sizing Data

Quality Attribute	VRP-032	VRP-048
Maximum Pressure	1,380 bar (20,015 psi)	700 bar (10,153 psi)
Maximum Flow Rate	25 l/min (5.5 gallons/min)	25 l/min (9.9 gallons/min)
Orifice Size	1/8", 3.2 mm	3/16", 4.8 mm
Ports	1/4" NPT (6.4 mm) up to 3/16" (14.3 mm) MP	1/2" NPT (12.7 mm) up to 1/4" NPT (19 mm)

Drawing and Material Specification

The image shown below is an example of one of the many sizes and options that we can offer. We can offer a range of sizes from 1/4" NPT to 1/2" NPT. There are also some options on materials for some items.

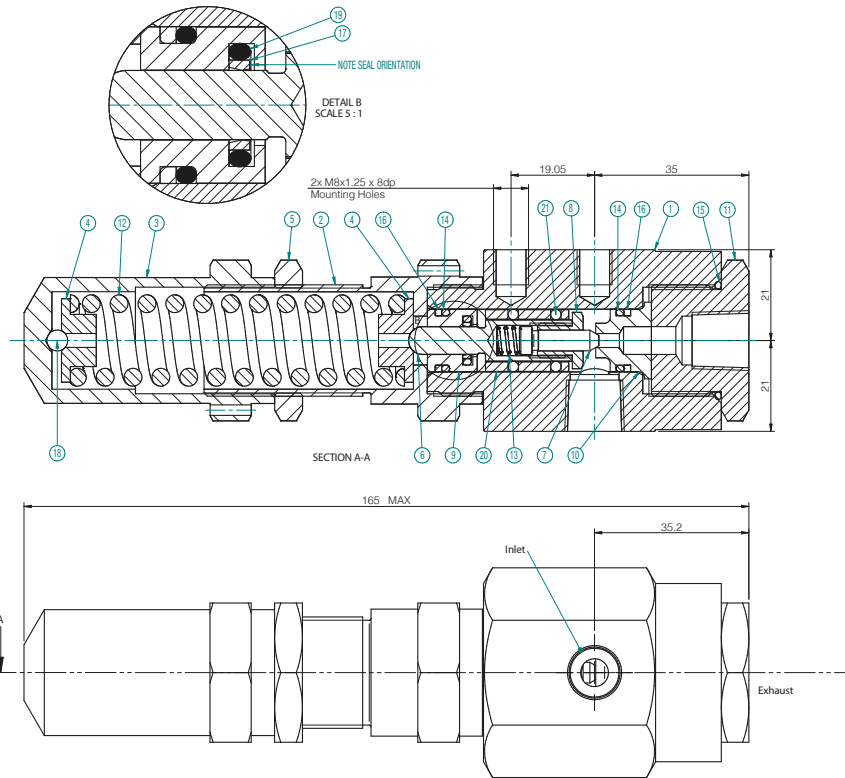

ITEM NO.	MATERIAL	QTY.
1	316S11 Stainless Steel BSEN10088-3 1.4404 to NACE MR-01-75	1
2	BS EN 10088-3 1.4404 Stainless Steel to NACE MR-01-75 (316S11)	1
3	BS EN 10088-3 1.4404 Stainless Steel to NACE MR-01-75 (316S11)	1
4	303 Stainless Steel	2
5	BS EN 10088-3 1.4404 Stainless Steel to NACE MR-01-75 (316S11)	1
6	431S29 Stainless Steel to BS970 Pt 3	1
7	M390 Stainless Steel	1
8	BS EN 10088-3 1.4404 Stainless Steel to NACE MR-01-75 (316S11)	1
9	Aluminium Bronze to BS2874: CA104	1
10	M340 Stainless Steel	1
11	316S11 Stainless Steel BSEN10088-3 1.4404 to NACE MR-01-75	1
12	302S26 Stainless Steel	1
13	316S11 Stainless Steel BSEN10088-3 1.4404 to NACE MR-01-75	1
14	Nitrile 90 Shore	2
15	Nitrile 90 Shore	1
16	P.T.F.E	2
17	UHMWPE	1
18	BS EN 10088-3 1.4404 Stainless Steel to NACE MR-01-75 (316S11)	1
19	Nitrile 70 Shore	1
20	Acetal	1
21	BS EN 10088-3 1.4404 Stainless Steel to NACE MR-01-75 (316S11)	12

A full listing of the Rotork sales and service network is available on our website.

www.rotork.com

Corporate Headquarters
Rotork plc

tel +44 (0)1225 733200
email mail@rotork.com

rotork®

Electric Actuators and Control Systems
Fluid Power Actuators and Control Systems
Gearboxes and Gear Operators
Precision Control and Indication
Projects, Services and Retrofit